

TTC7

#30120 RC10TC7 Factory Team Kit

FACTORY
Team



1:10 Scale Electric 4WD Touring Car Kit Manual & Catalog

TEAM ASSOCIATED



Designed in California, USA

:: Introduction

Thank you for purchasing this Team Associated product. This assembly manual contains instructions and tips for building and maintaining your new RC10TC7. Please take a moment to read through this manual to help familiarize yourself with these steps.

We are continually changing and improving our designs; therefore, actual parts may appear slightly different than in the illustrations. New parts will be noted on supplementary sheets located in the appropriate parts bags. Check each bag for these sheets before you start to build.

:: KIT Features

Team Associated is proud to release its next generation of 1:10th scale 4WD electric touring car kits, the RC10TC7-FT, evolving forward for the most refined package to date.

The touring car racing class has matured to a competition level higher than ever before, and the Engineers behind the doors of Area-51 have been hard at work to make sure the TC7 can keep pace. The RC10TC7-FT car kit comes packed full of Factory Team options and a refined suspension package with precise adjustment resulting in a level of consistency to be unequalled.

With over four year's development on the TC6 chassis, the RC10TC7-FT car kit rolls forward including all the Factory Team test parts Area-51 has had in the works for the last several years. The focus was on a more precise feel with updates in suspension component composites and ultra-smooth FOX with Genuine Kashima Coated shock bodies. The floating servo controls an updated dual bellcrank steering system with a low center of gravity and refined Ackermann range allowing the most direct steering feeling for any track condition. Updated motor mount is centrally located to produce the most consistent chassis flex and accurate gear alignment to help keep cornering as efficient as possible. The RC10TC7-FT gives you all the key features and options necessary to keep you at the top of the racing circuit. All without sacrificing low part count or affordability. With its prototype sweeping the modified podium at 2015 ROAR Paved Nationals, it's easy to see that the RC10TC7-FT kit is... another "Champion by Design" from Team Associated!

:: Key Features

- Updated suspension geometry
 - Carbon composite material used for the best combination of strength at minimized mass
 - Optimized suspension arm length and shock mounting positions
 - Pivot ball on inner hinge pin allows free pin movement at any toe or kickup angle
 - Insert system for precise adjustment of toe and inner pin width
 - Independent arm mount design to allow maximum flex through entire chassis length, resulting in better grip on all track conditions
- FOX with Genuine Kashima Coated shock bodies
 - Ultra-smooth Kashima Hard Coating for minimal friction and extended wear
 - Hard coated shock shafts with polished finish
 - Machined piston and bushing sets for the most precise build
 - Updated bladder profile for consistent performance
- New one-piece motor mount
 - Central mounting to allow free chassis flex in either direction
 - One-piece design ensures proper spur/pinion gear alignment
 - Floating spur helps to center flex point of top plate giving better overall traction
- Updated drive belts
 - Optimized length for better on power steering
 - Softer material for a more efficient drive-train
- Updated dual bellcrank steering system
 - Low profile mounting for an overall lower center of mass
 - Optimized Ackermann and steering rates
 - Horizontal ballstuds for fine Ackermann adjustments
 - 8 precision bearings for accurate swing motion
- Floating servo mount
 - Servo mounts to chassis center to allow equal chassis flex in both directions and a tweak free assembly
 - Mount ties to steering bellcrank posts for stable servo positioning
 - Slotted servo mount design allows fit for almost any servo size
- Narrow chassis with optimized flex characteristics
 - 2.25mm graphite laminate for optimized flex characteristics
 - A narrow 88mm wide to minimize chassis dragging at maximum chassis roll angles
 - Chassis ballast mass mounting locations to fine tune mass balance
- Vertical ball stud bearing caps
 - Optimized position for inner ball stud
 - Vertical ballstud orientation allows for fine adjustments of roll center height
 - 3 link position options give precise control of camber gain
- Rear gear diff for maximum performance and minimal maintenance
 - Lightweight design
 - Durable composite construction
 - Optimized for a wide "tuning window" to maximize useable adjustability
 - Hard anodized aluminum outdrives for low wear and long life
- Front spool with replaceable composite outdrives
 - Outdrives allow the use of existing CVA bone blades to minimize binding at the bearing surface
 - Composite outdrives are replaceable at low cost in the event of a CVA bone blade failure
- Titanium turnbuckles with turnbuckle eyelets for easy access to ball stud for adjustment
- 22 precision ball bearings

:: Items Needed

Your new FT TC7 comes unassembled and requires the following items for completion. (refer to catalog section for suggestions):

- 1:10th scale electric motor and electronic speed control
- 3.7V-7.4V LiPo, 6.6V LiFe, or 4.8V-7.2V NiMh/NiCd battery
- Battery charger (suited for, and particular to, one of the batteries mentioned)
- 2 channel surface transmitter, 2 channel receiver, and steering servo
- 1:10th scale 190mm polycarbonate touring car body
- Polycarbonate specific paint for body
- Strapping tape for battery
- 1:10th scale rubber (or foam) touring car tires, wheels and inserts

:: Other Helpful Items

- Silicone Shock Fluid (Refer to catalog for complete listings)
- Silicone Diff Fluid (Refer to catalog for complete listings)
- Thread Lock (AE Part #1596)
- Body Scissors (AE Part # 1737)
- Reamer / Hole Punch
- FT Hex Wrenches (AE Part # 1541)
- FT Nut Drivers (AE Part# 1561)
- Needle Nose Pliers
- Wire Cutters/ Hobby Knife
- Soldering Iron
- Calipers or a Precision Ruler

Associated Electrics, Inc.
26021 Commercentre Dr.
Lake Forest, CA 92630







Customer Service
Tel: 949.544.7500
Fax: 949.544.7501

:: Hardware - 1:1 Scale View













Cap Head (shcs)

-  **1.6x5mm (91611)**
-  **2x5mm (31511)**



Set screw

-  **3x2.5mm (31500)**
-  **3x3mm (25225)**
-  **3x8mm (4670)**
-  **4x8mm (25227)**





Ball studs

-  **Ti Nitride 3.25mm short (31374)**
-  **Black 5mm short (31280)**
-  **Ti Nitride 5mm short (31288)**
-  **Silver 5mm long (31283)**
-  **Ti Nitride 5mm long (31291)**
-  **Black 8mm short (31281)**
-  **Ti Nitride 8mm short (31289)**
-  **Silver 8mm long (31284)**
-  **Ti Nitride 8mm long (31292)**
-  **Black 10mm short (31285)**
-  **Ti Nitride 10mm short (31290)**
-  **Silver 10mm long (31285)**
-  **Ti Nitride 10mm long (31293)**

Nuts (lock/plain)

-  **M3 locknut (31550)**
-  **M4 locknut (91148)**







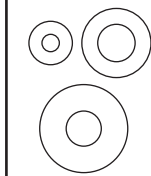





Flat Head (fhcs)

-  **2.5x6mm (4675)**
-  **2.5x10mm (31350)**
-  **3x6mm (31541)**
-  **3x8mm (25201)**
-  **3x10mm (25202)**





Shims and Washers

-  **1mm and 2mm blue shims (31286)**
-  **Washer (7337)**
-  **Bulkhead Shim (4617)**
0.5mm, 1mm, 2mm
-  **Axle & Diff shim (31162)**
-  **Gear Diff Shims (31348)**

Button Head (bhcs)

-  **2x4mm (31510)**
-  **2x5mm (31511)**
-  **2.5x4mm (4673)**
-  **2.5x6mm (31520)**
-  **2.5x8mm (31521)**
-  **3x5mm (31530)**
-  **3x6mm (31531)**
-  **3x8mm (31532)**
-  **3x10mm (25211)**
-  **3x12mm (89202)**
-  **3x14mm (25187)**
-  **3x16mm (89203)**

Ball Bearings

-  **4x7mm (31403)**
-  **4x8x3mm flanged (31331)**
-  **5x8mm (31400)**
-  **5x10x4mm (91560)**
-  **10x15x4mm (91563)**

Notes:

:: Table of Contents

1.....Cover	13-16.....Bulkheads, Spur Gear, and Steering Rack Build (Bags 12, 13)
2.....Introduction	
3.....1:1 Hardware “Fold Out”	16-19.....Caster Blocks/Rear Hubs Build (Bags 14, 15, 16)
4.....Table of Contents	19-23.....Bumper, Anti Roll Bar, and Electronics Build (Bags 17, 18)
5-6.....Shock Build (Bags 1, 2)	24-26.....Tuning Tips
6-9.....Spool and Differential Build (Bags 3, 4, 5)	27.....Gear Chart
9.....Turnbuckle Build (Bag 6)	28-35.....Catalog
9.....CVA Build (Bag 7)	36.....Setup Sheet “Kit Setup”
11-12.....Suspension Arms Build (Bags 8, 9, 10, 11)	37.....Setup Sheet “Blank”
	38.....Back Cover

:: Notes

This symbol indicates a special note or instruction in the manual.



This symbol indicates a Racers Tip.



Scanning this QR code will take you to Team Associated’s Tech Tips videos. These videos will help you with your build and setup!



There is a 1:1 hardware foldout page in the front of the manual. To check the size of a part, line up your hardware with the correct drawing until you find the exact size. Each part in the foldout has a number assigned to it for ordering replacement parts.

**Associated Electrics, Inc.
26021 Commercentre Dr.
Lake Forest, CA 92630**



**Customer Service
Tel: 949.544.7500
Fax: 949.544.7501**

:: Shock Build - Bag 1 & 2 - Step 1

31510
M2x4mm
bhcs

#1596
thread lock

31689
TC7 shock
piston
(3x1.1)

21139
Steel washer
(2.6x6x0.5mm)

31688
TC7 shock
shaft

31687
TC7 FT
shock body
(Fox
Kashima
Coat)

31327
VCS3 shock
bottom cap
o-ring

**Shock fluid
#5433
(37.5wt)**

5407
Red
o-rings

31693
TC7 shock
shaft
bushing

31327
VCS3 shock
bottom cap

**Thread lock
not included!**

**Build four
shock shafts**

:: Shock Build - Bag 1 & 2 - Step 2

31700
TC7 shock
eyelet

4637
FT pivot
balls

**Shock fluid
#5433
(37.5wt)**

31700
TC7 shock
cap

4637
FT pivot
balls

31693
TC7
bladder

**Build four
shocks**

:: Shock Build - Bag 1 & 2 - Step - 3

31696
TC7
shock cap
retainer

**Shock oil
#5423
(40wt)**

31326
VCS3 shock
collar o-ring

31326
VCS3
shock collar

Bladder Installation

**Build four
shock collars**

**Build four
shocks**

With the shaft extended 25%, place bladder on the top of the shock body, displacing the extra oil. While maintaining pressure on the bladder against the shock body, carefully lift one side of the bladder to allow any extra oil to escape. Place shock cap on top of bladder, and secure it by threading the aluminum cap retainer onto the shock body.

:: Shock Build - Bag 1 & 2 - Step 4

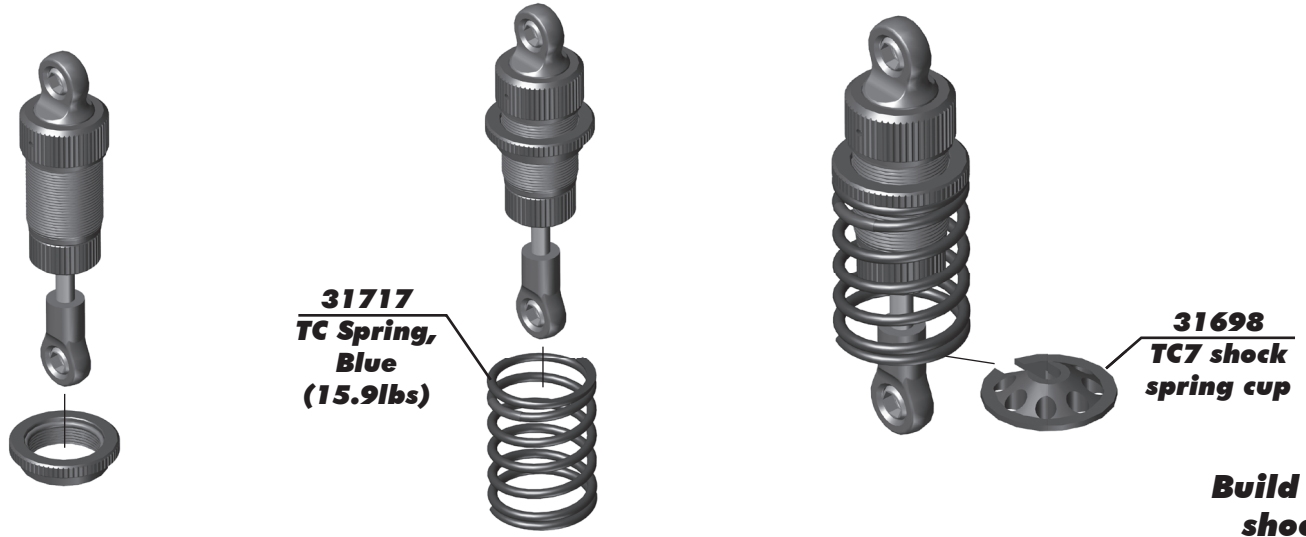

:: Spool and Differential Build - Bag 3, 4 & 5 - Step 1

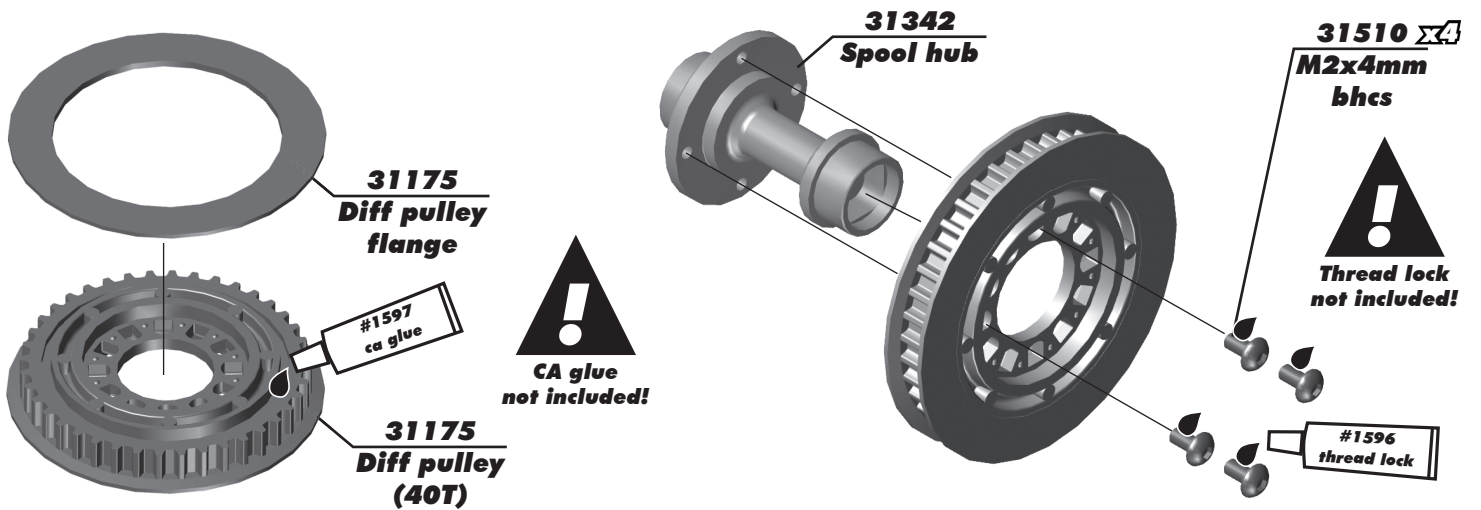

:: Spool and Differential Build - Bag 3, 4 & 5 - Step 2

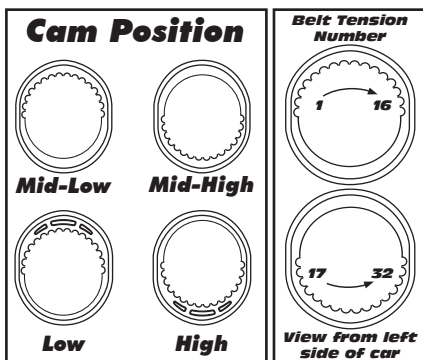

Note!
Always use the same cam position on both sides of the car.

Left Side

Use belt tension position 8 for standard setup on the front.

Right Side

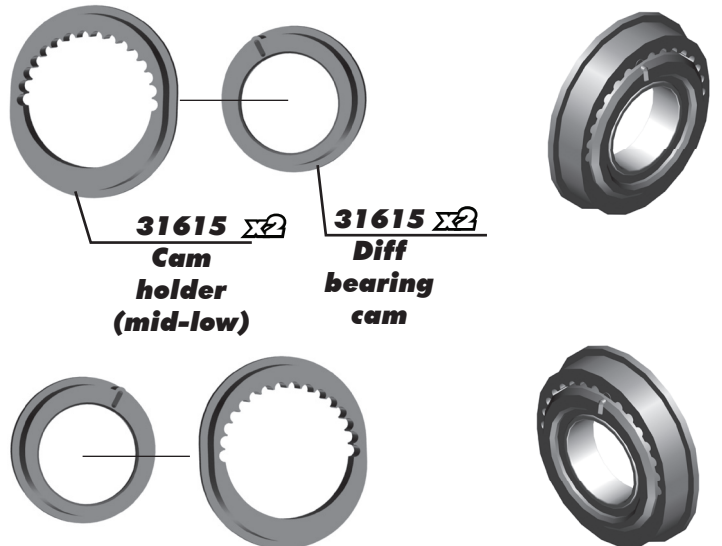

:: Spool and Differential Build - Bag 3, 4 & 5 - Step 3

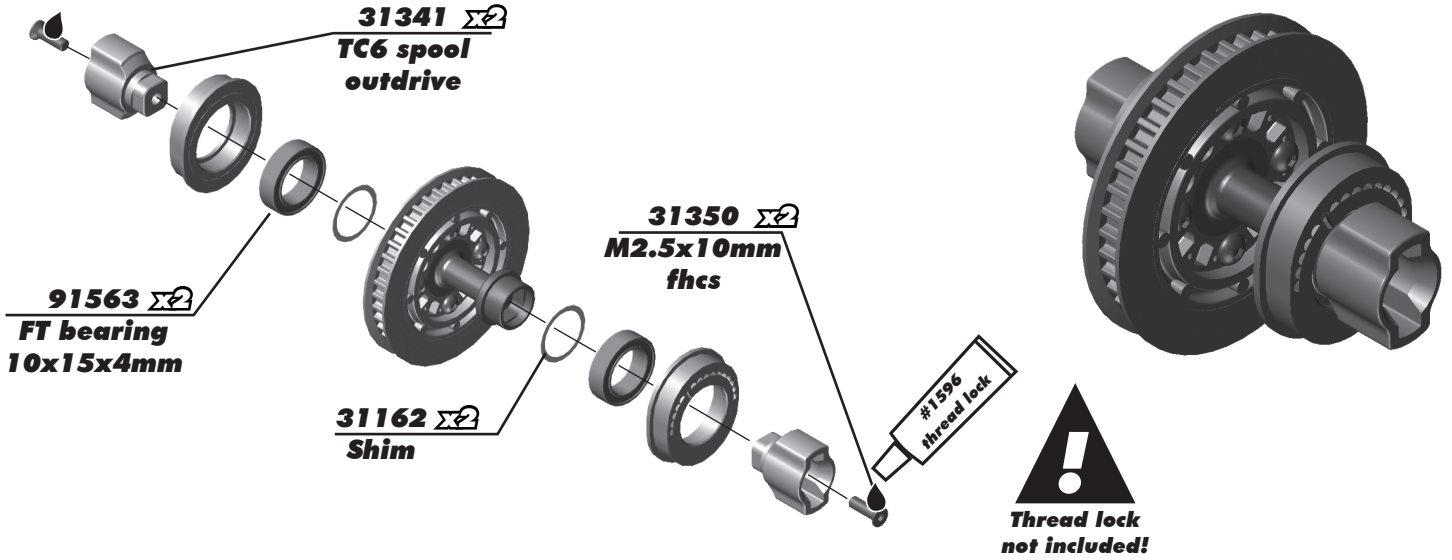

:: Spool and Differential Build - Bag 3, 4 & 5 - Step 4

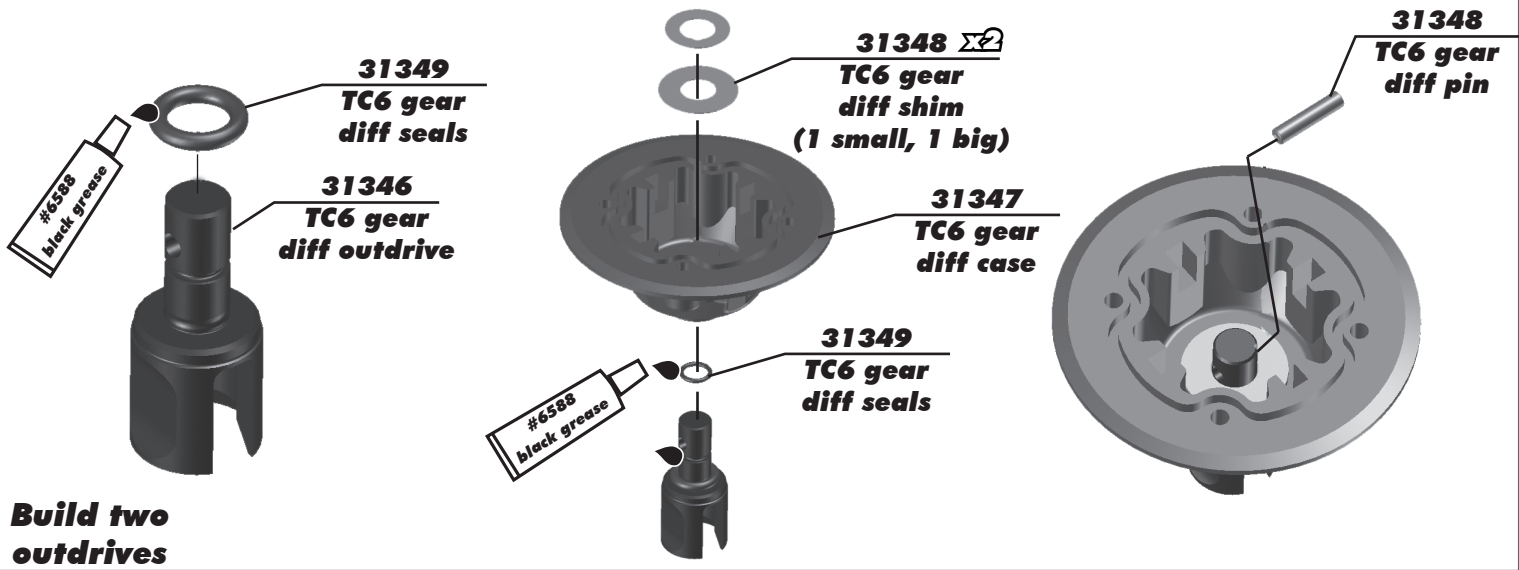

:: Spool and Differential Build - Bag 3, 4 & 5 - Step 5

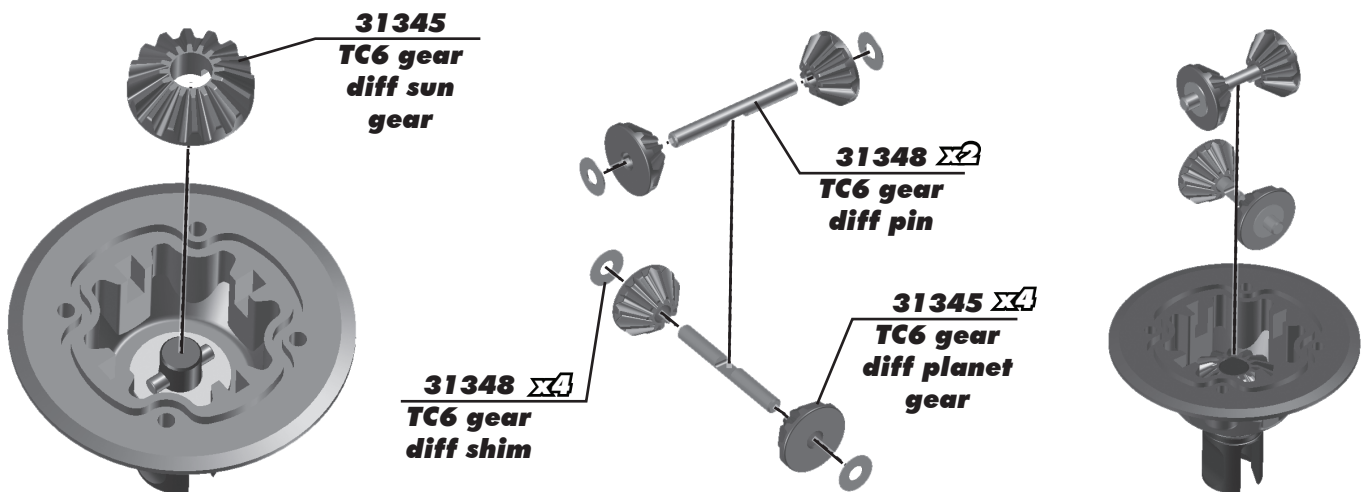

:: Spool and Differential Build - Bag 3, 4 & 5 - Step 6

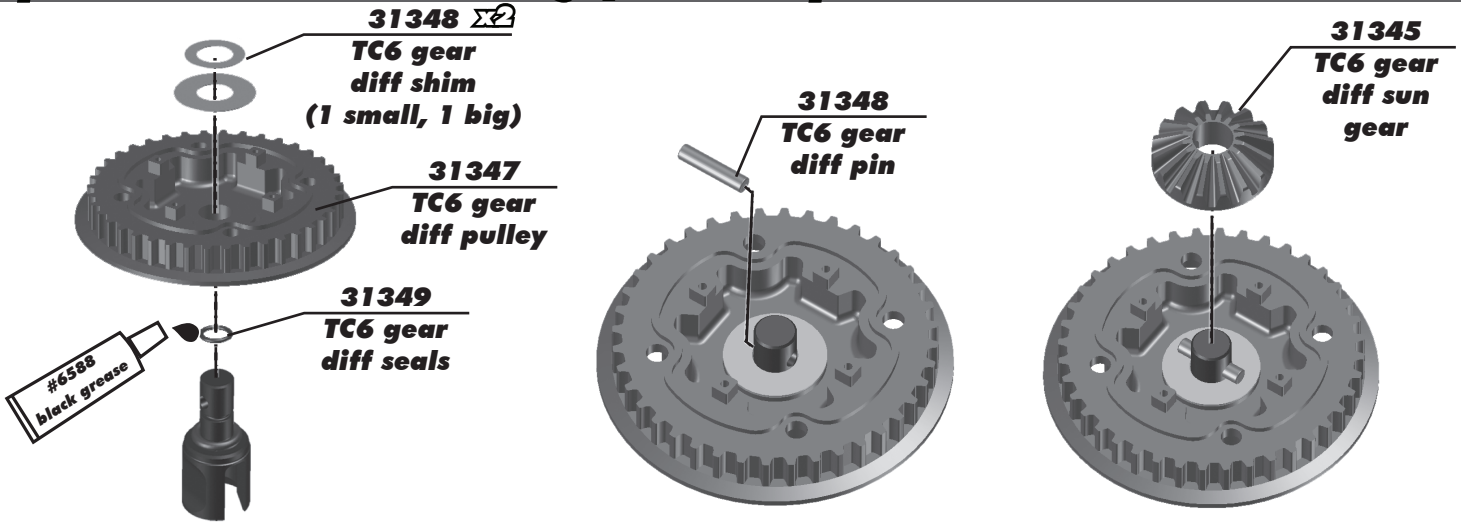

:: Spool and Differential Build - Bag 3, 4 & 5 - Step 7

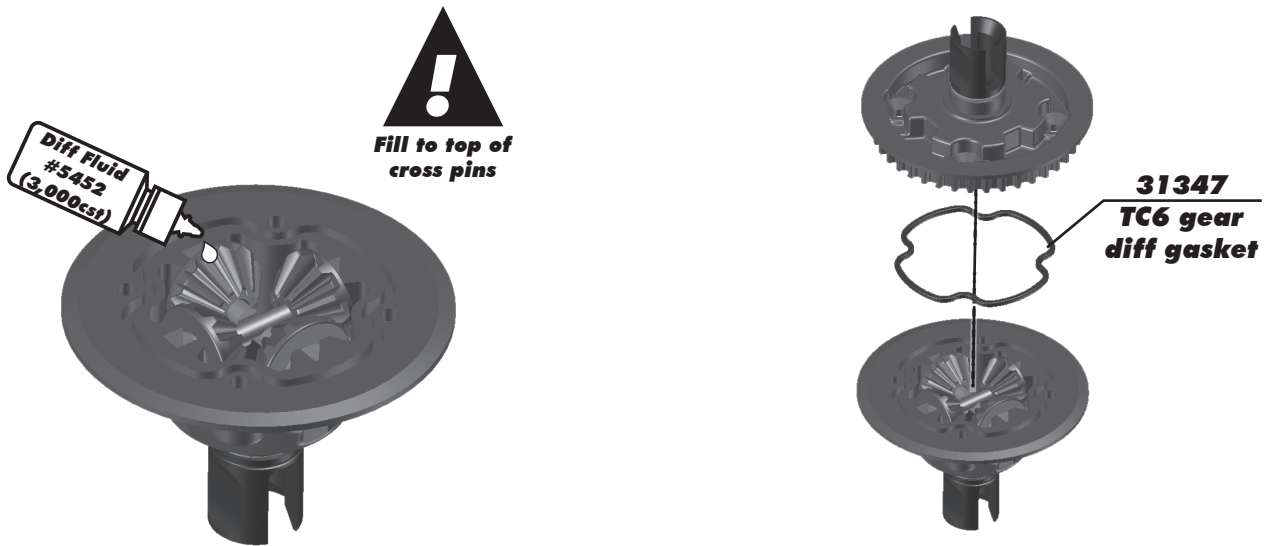

:: Spool and Differential Build - Bag 3, 4 & 5 - Step 8

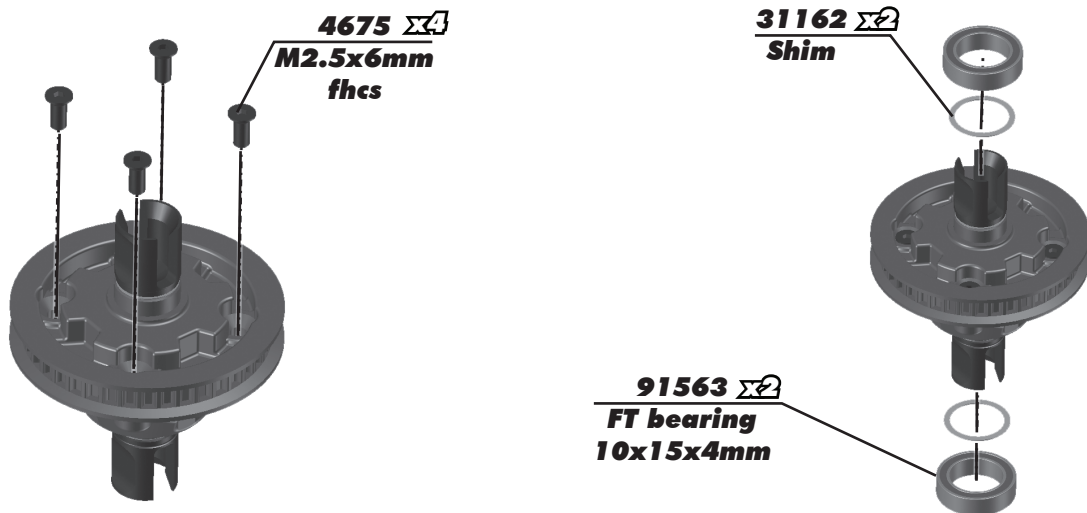

:: Spool and Differential Build - Bag 3, 4 & 5 - Step 9

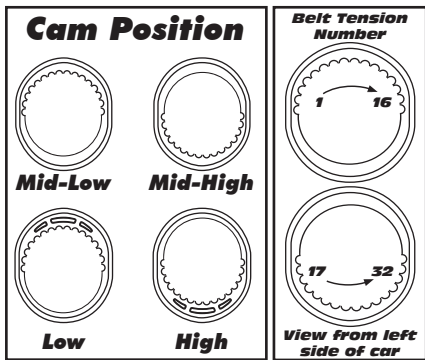

Note!
Always use the same cam position on both sides of the car.

Left Side

Use belt tension position 7 for standard setup on the rear.

Right Side

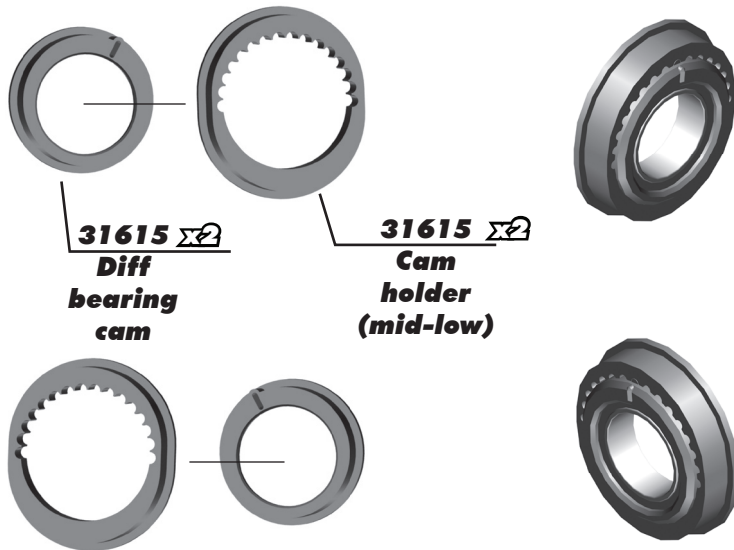

:: Spool and Differential Build - Bag 3, 4 & 5 - Step 10

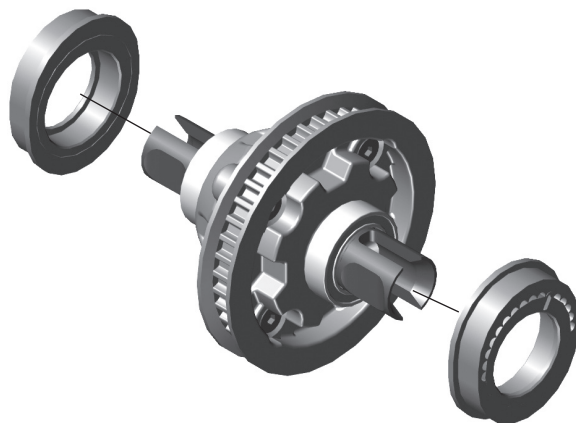

:: Turnbuckles Build - Bag 6 - Step 1

Servo Turnbuckle

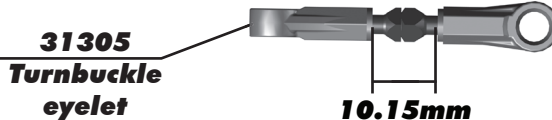
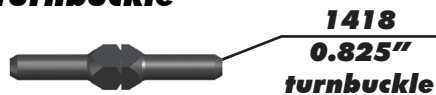

Camber Turnbuckle

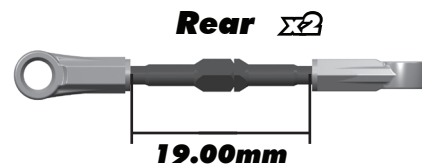
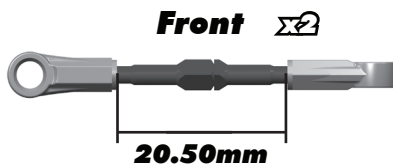

Steering Turnbuckle

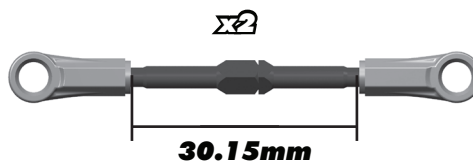

:: CVA Build - Bag 7 - Step 1

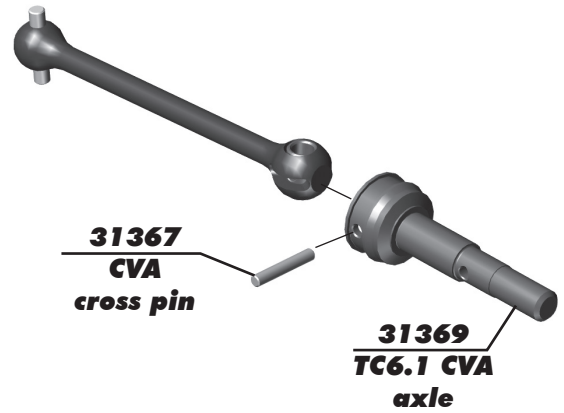
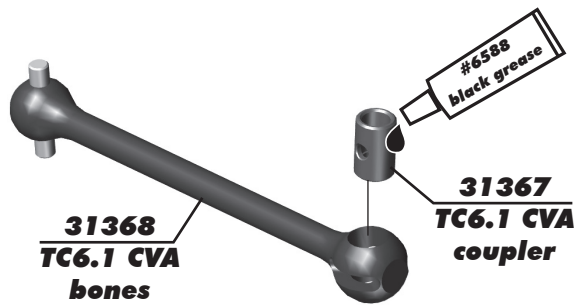

:: CVA Build - Bag 7 - Step 2

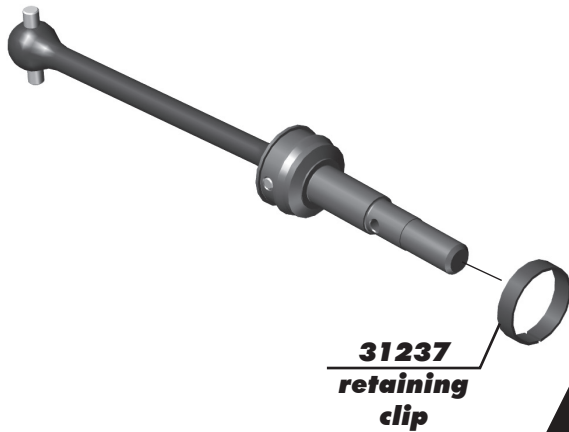

RACERS TIP!
place a drop of CA glue
on the pin retainer gap.



Note!
Align the gap in the
pin retainer to be
opposite of the CVA pin.

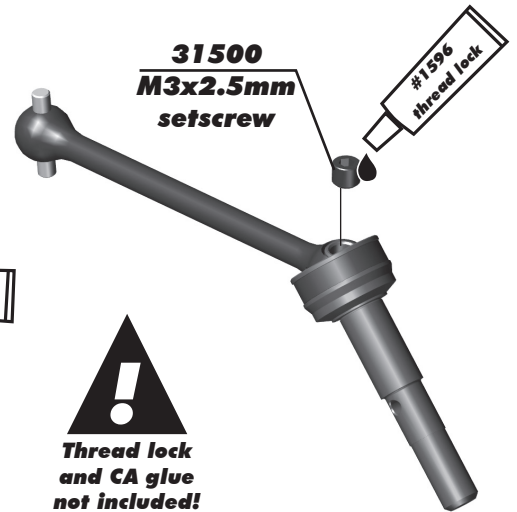

**Thread lock
and CA glue
not included!**

:: CVA Build - Bag 7 - Step 3

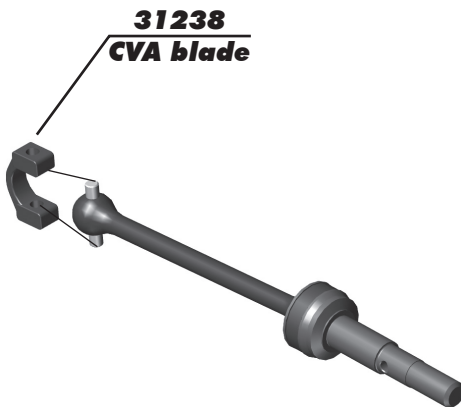

**Build four
CVA's**

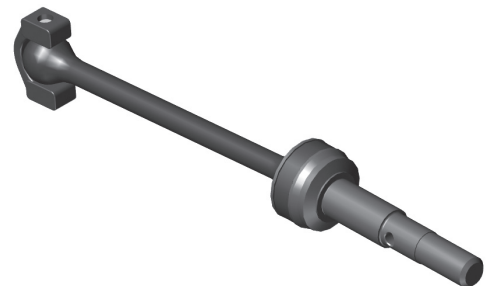

:: Suspension Arms Build - Bag 8, 9, 10, & 11 - Step 1

Build four inner arm mounts

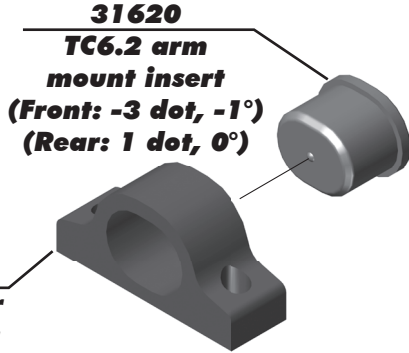

31619 TC6.2 Inner arm mount

31620 TC6.2 arm mount insert
(Front: -3 dot, -1°)
(Rear: 1 dot, 0°)

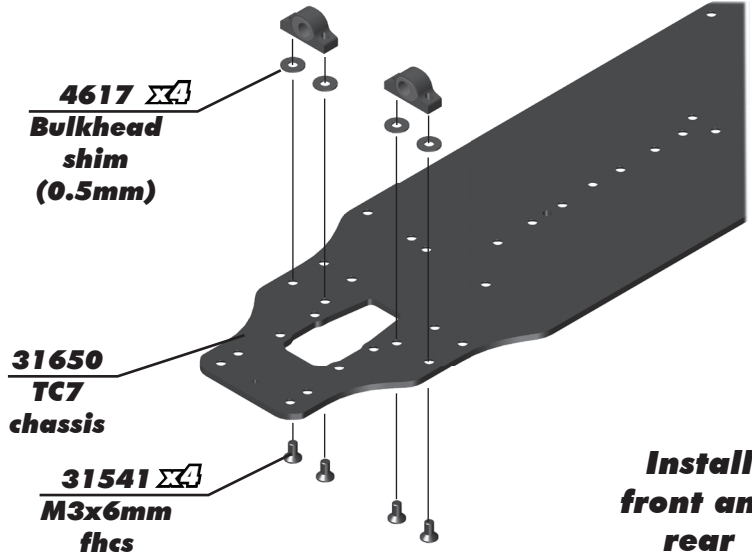
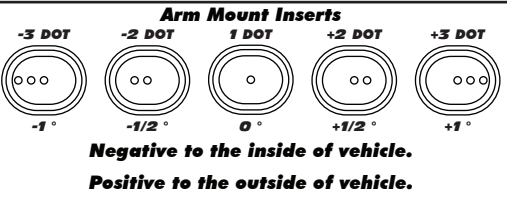

4617 x4 Bulkhead shim (0.5mm)

31650 TC7 chassis

31541 x4 M3x6mm fuchs

Install front and rear

:: Suspension Arms Build - Bag 8, 9, 10, & 11 - Step 2

Build left and right sides

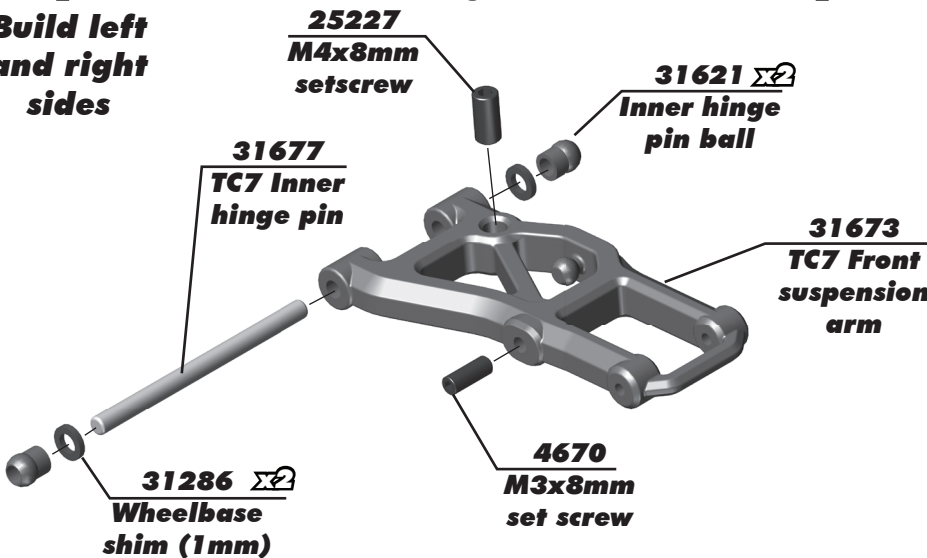

25227 M4x8mm setscrew

31621 x2 Inner hinge pin ball

31677 TC7 Inner hinge pin

31673 TC7 Front suspension arm

31286 x2 Wheelbase shim (1mm)

4670 M3x8mm set screw

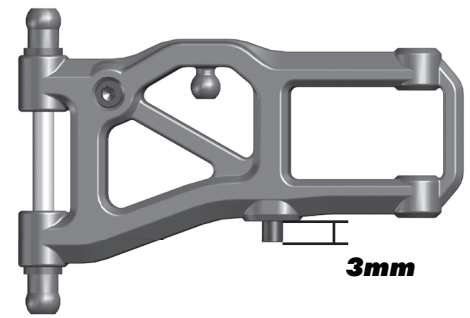

3mm

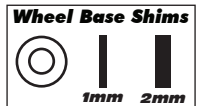

:: Suspension Arms Build - Bag 8, 9, 10, & 11 - Step 3

Build left and right sides

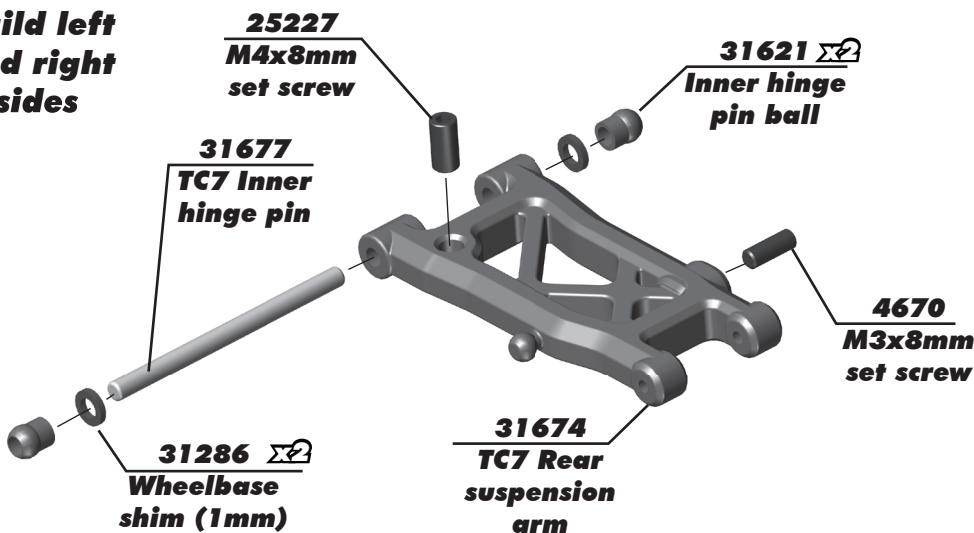

25227 M4x8mm set screw

31621 x2 Inner hinge pin ball

31677 TC7 Inner hinge pin

4670 M3x8mm set screw

31286 x2 Wheelbase shim (1mm)

31674 TC7 Rear suspension arm

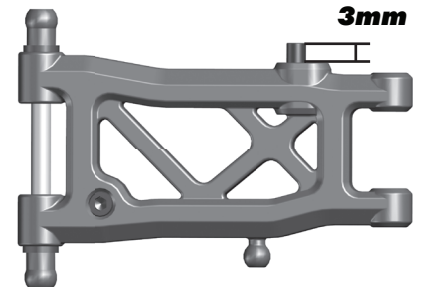

3mm

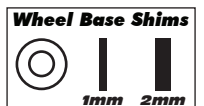

:: Suspension Arms Build - Bag 8, 9, 10, & 11 - Step 4

31620 X2
**TC6.2 arm
 mount insert**
 (-3 dot, -1°)

**Build two, one for
 front, one for rear.**
(Front: -3 dot, -1°)
(Rear: 1 dot, 0°)

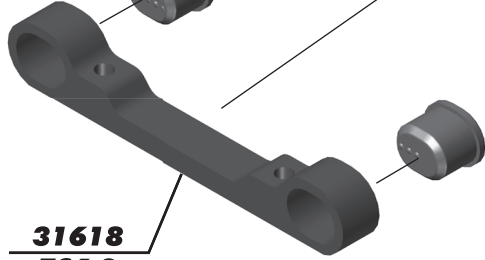

31618
TC6.2
**Outer Arm
 Mount**

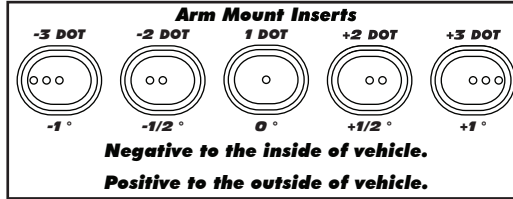
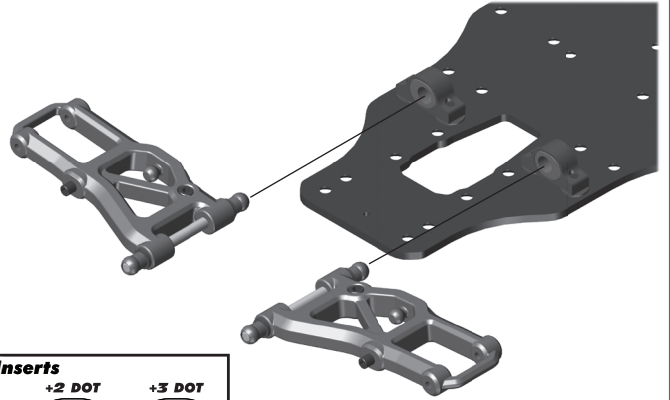

:: Suspension Arms Build - Bag 8, 9, 10, & 11 - Step 5

4617 X2
**Bulkhead
 shim**
 (0.5mm)

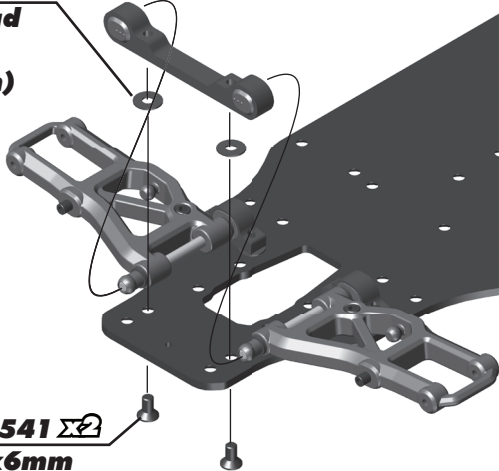

31541 X2
**M3x6mm
 fhs**

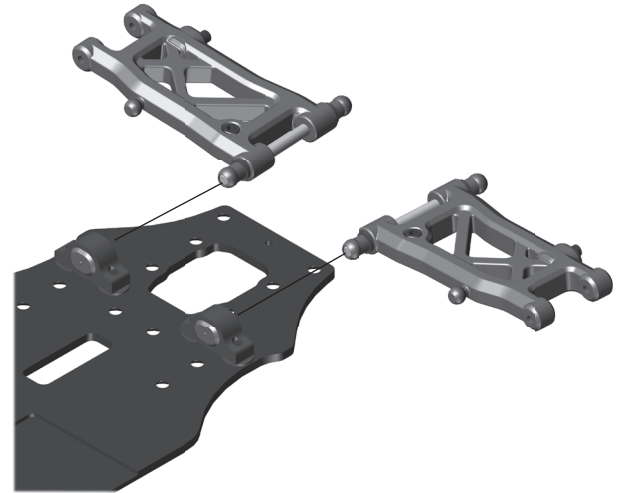

:: Suspension Arms Build - Bag 8, 9, 10, & 11 - Step 6

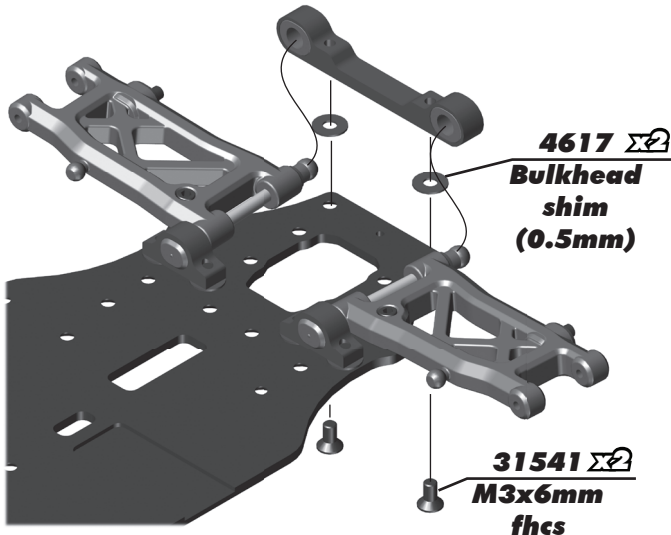

4617 X2
**Bulkhead
 shim**
 (0.5mm)

31541 X2
**M3x6mm
 fhs**

Droop:

The standard settings of 6mm front and 5mm rear will work best in most cases. Droop is measured just underneath the outer hinge pin as shown in the photos to the right.

On bumpy or low grip surfaces, increase the droop (going to a lower number on the droop gauge), this will help increase traction and consistency.

Droop adjustments of 0.5mm to 1mm can be very effective on the track!

**Front Droop
 Setting: 6mm**



**Rear Droop
 Setting: 5mm**

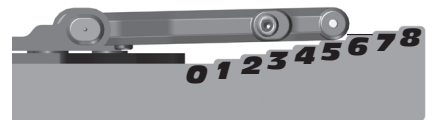

:: Bulkheads, Spur Gear, and Steering Build - Bag 12 & 13 - Step 1

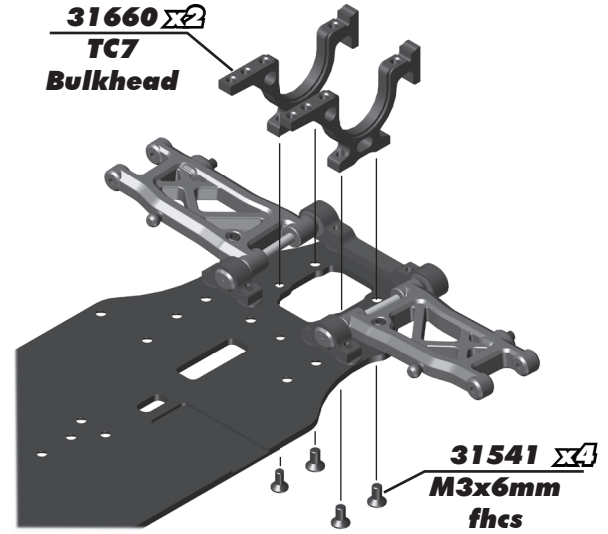
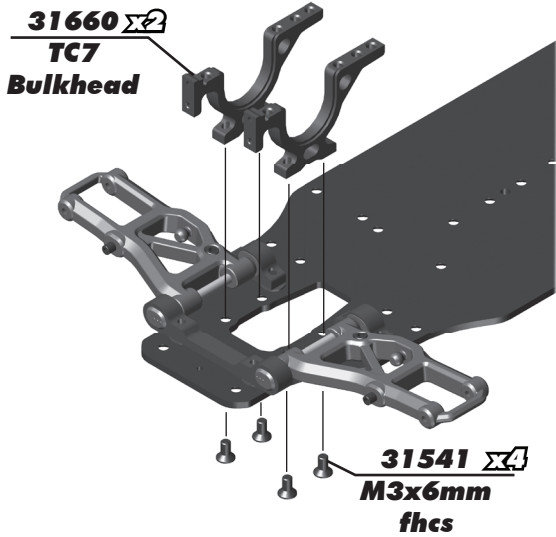

:: Bulkheads, Spur Gear, and Steering Build - Bag 12 & 13 - Step 2

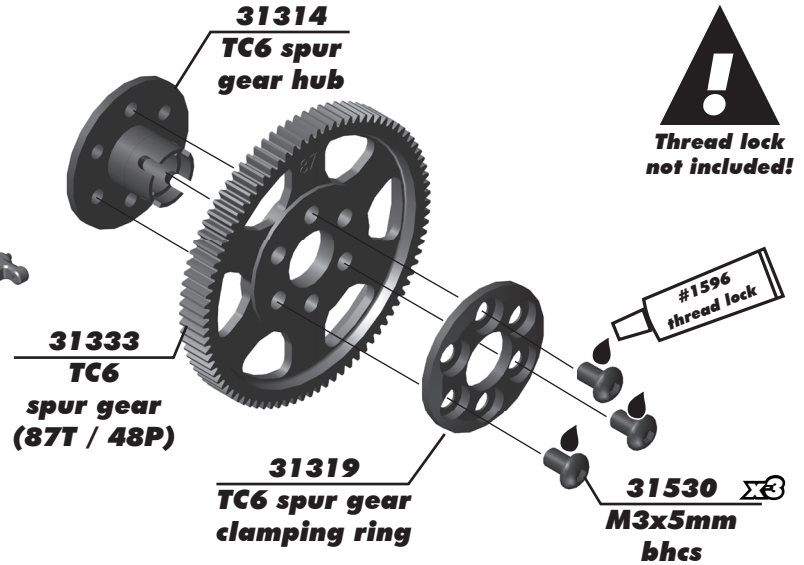
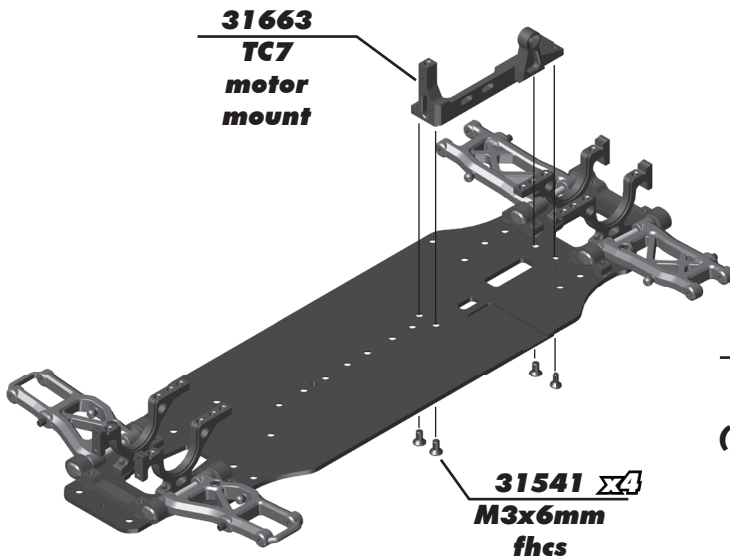

:: Bulkheads, Spur Gear, and Steering Build - Bag 12 & 13 - Step 3

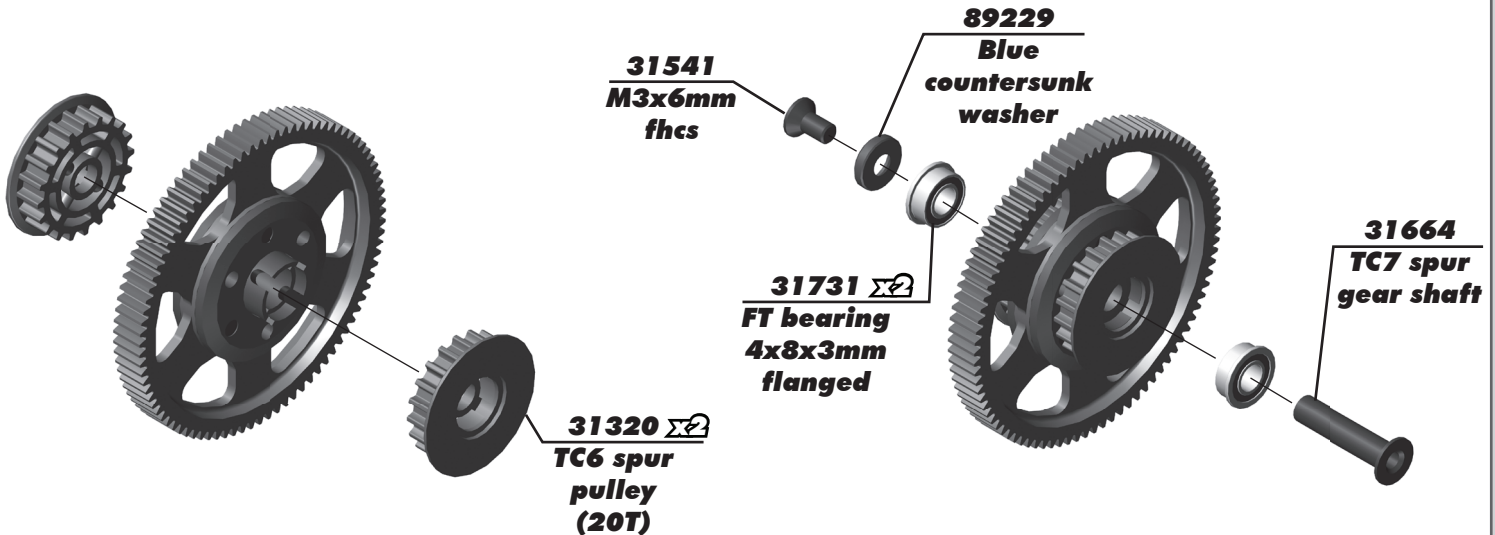

:: Bulkheads, Spur Gear, and Steering Build - Bag 12 & 13 - Step 4

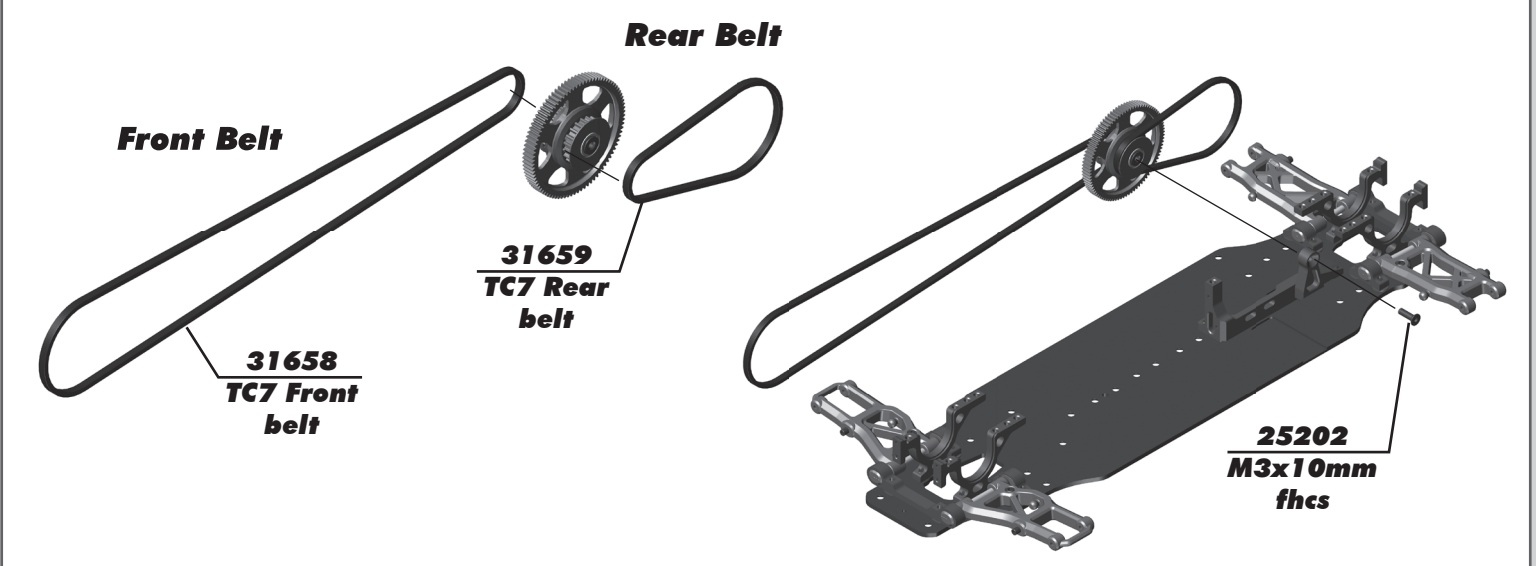

:: Bulkheads, Spur Gear, and Steering Build - Bag 12 & 13 - Step 5

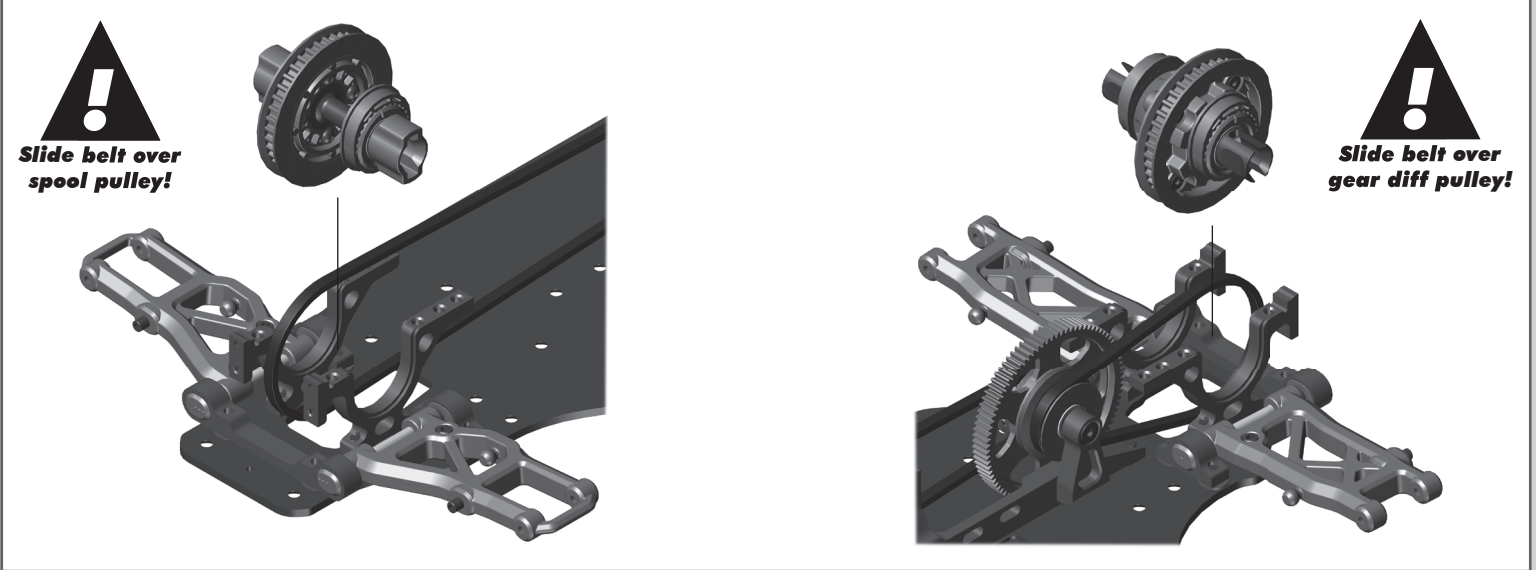

:: Bulkheads, Spur Gear, and Steering Build - Bag 12 & 13 - Step 6

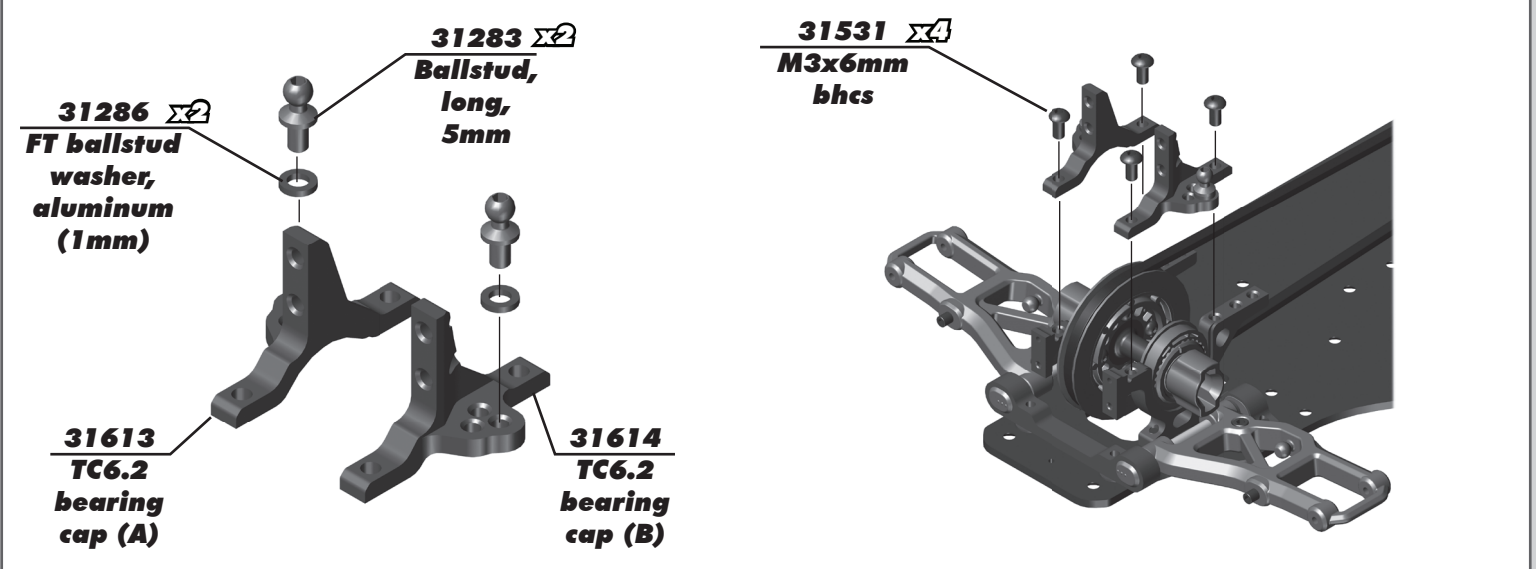

:: Bulkheads, Spur Gear, and Steering Build - Bag 12 & 13 - Step 7

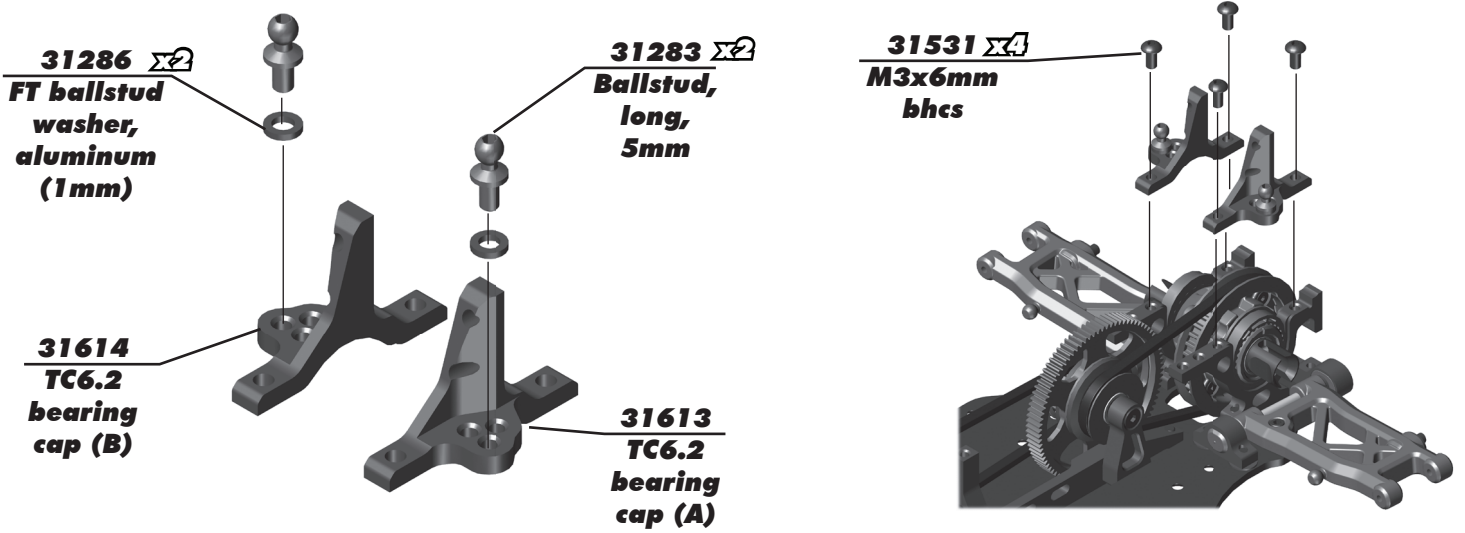

:: Bulkheads, Spur Gear, and Steering Build - Bag 12 & 13 - Step 8

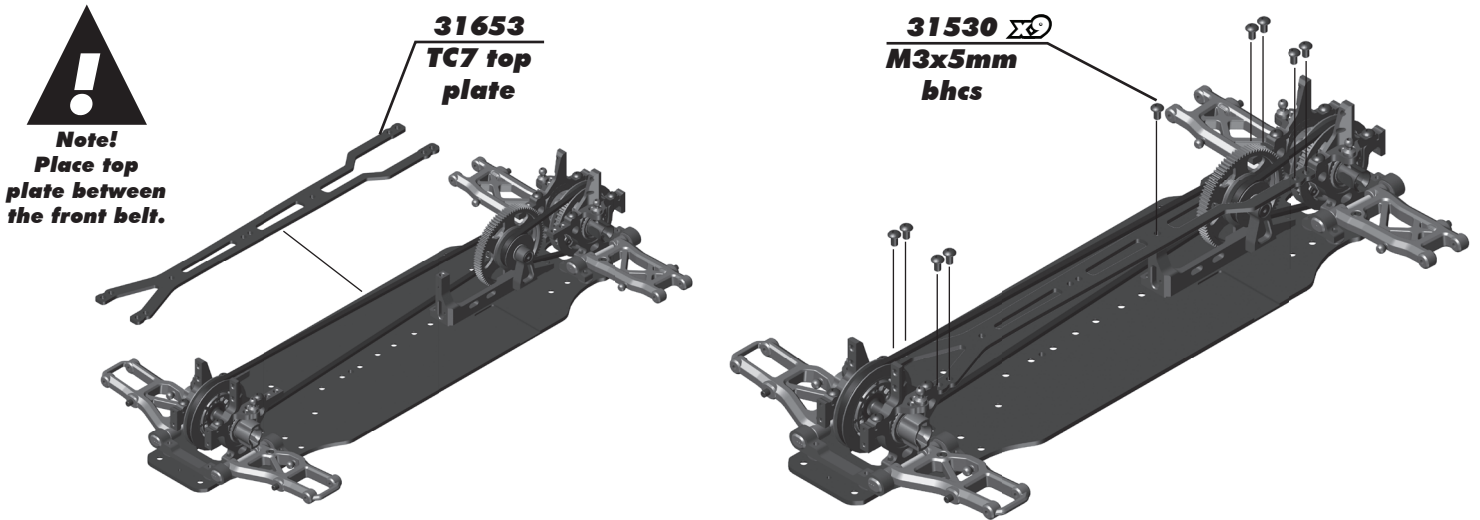

:: Bulkheads, Spur Gear, and Steering Build - Bag 12 & 13 - Step 9

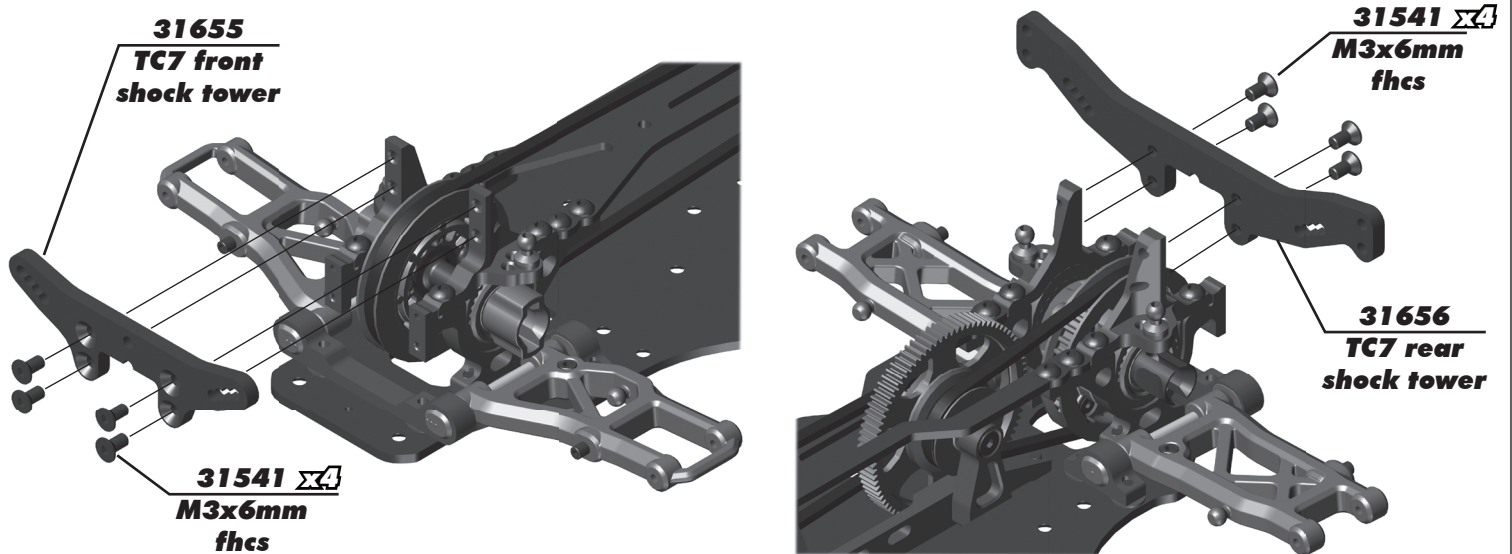

:: Bulkheads, Spur Gear, and Steering Build - Bag 12 & 13 - Step 10

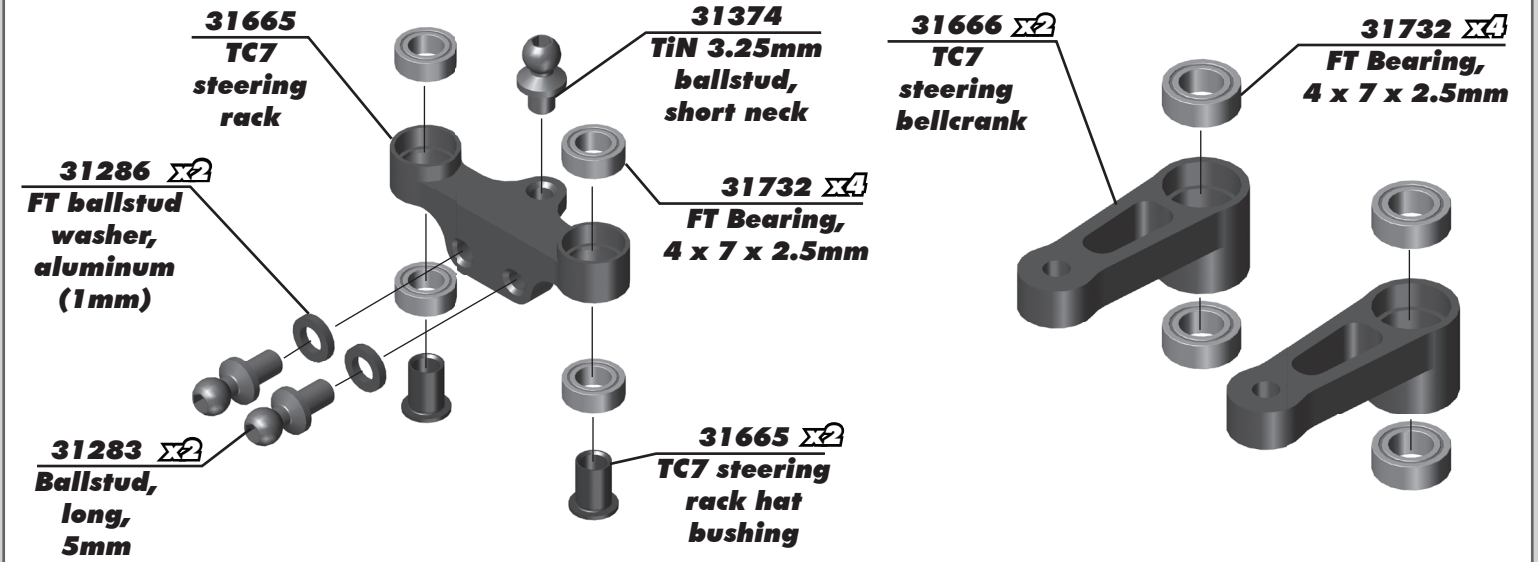

:: Bulkheads, Spur Gear, and Steering Build - Bag 12 & 13 - Step 11

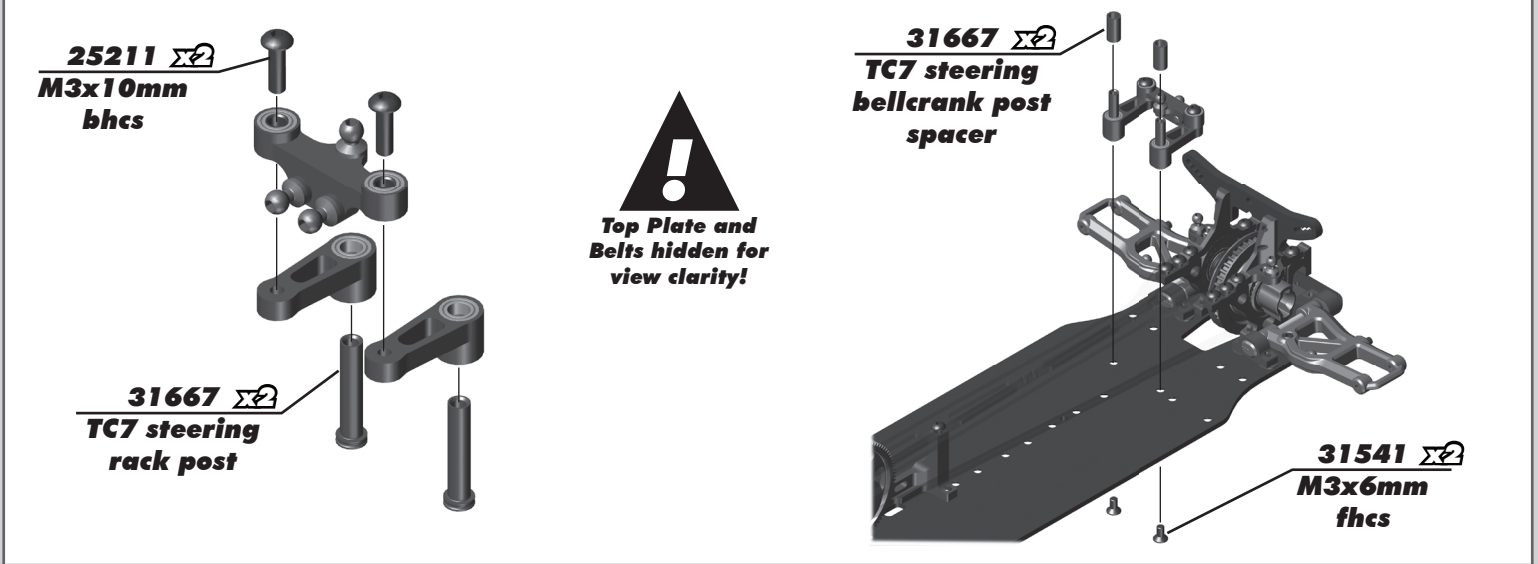

:: Caster Blocks and Hubs Build - Bag 14, 15, & 16 - Step 1

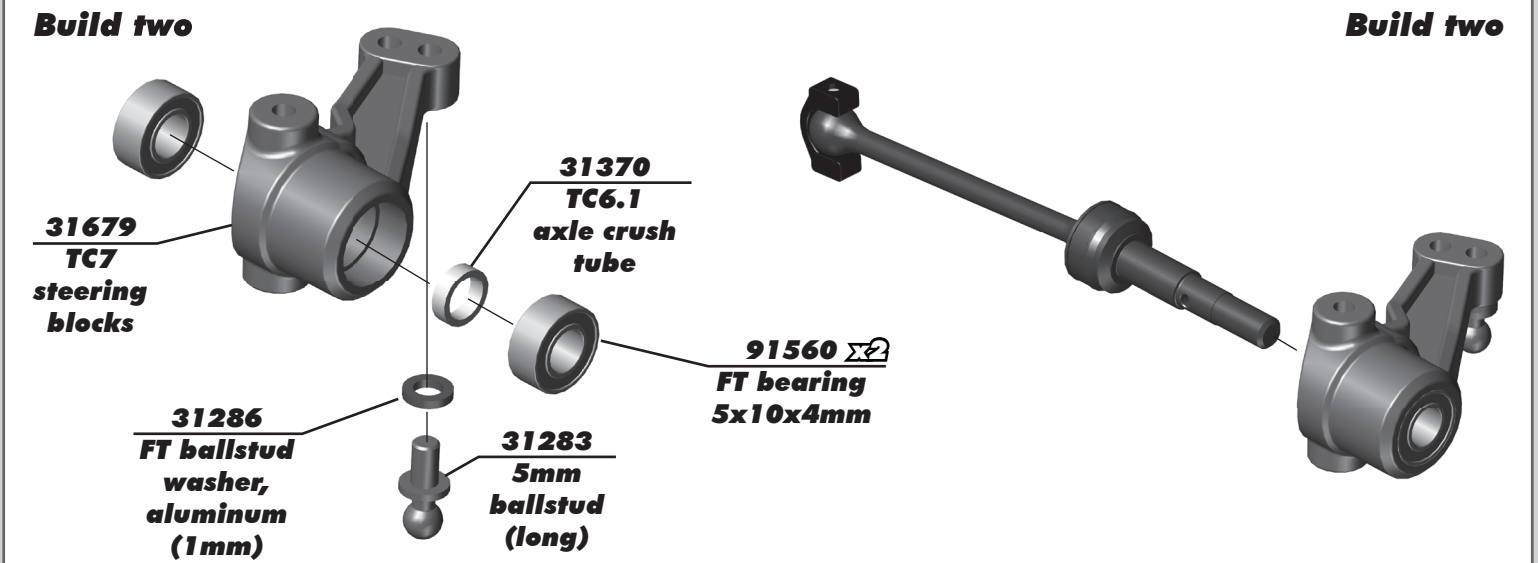

:: Caster Blocks and Hubs Build - Bag 14, 15, & 16 - Step 2

Build two

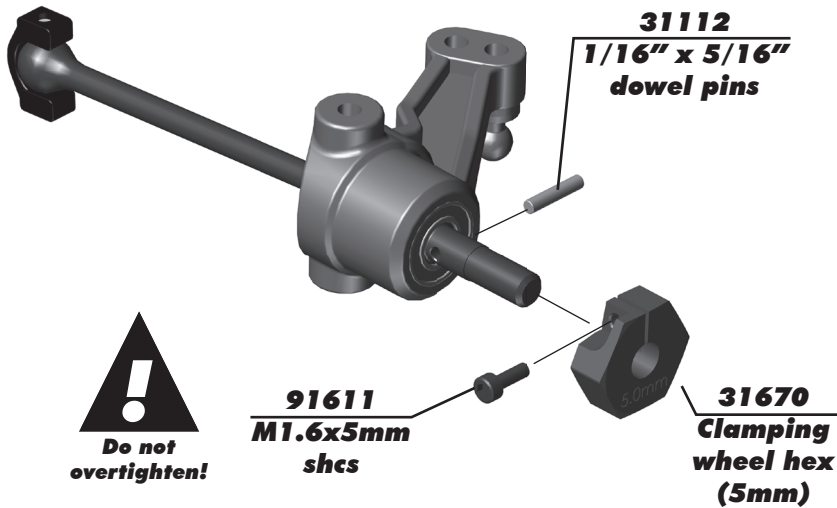

Use a 1.5mm hex tool tip to poke through any left over flashing (extra thin piece of plastic) in the hinge pin set screw hole on the caster blocks.

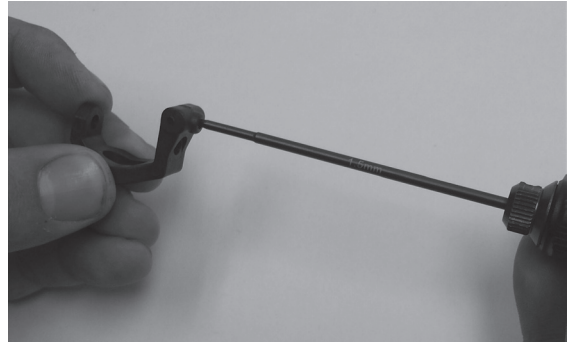

:: Caster Blocks and Hubs Build - Bag 14, 15, & 16 - Step 3

Build two

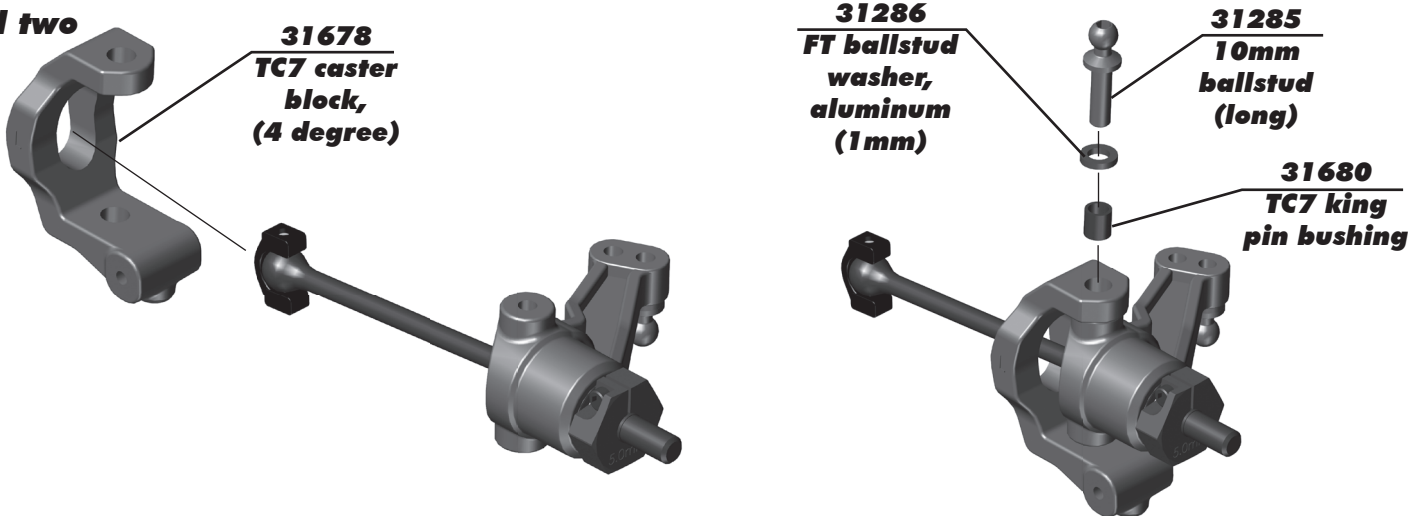

:: Caster Blocks and Hubs Build - Bag 14, 15, & 16 - Step 4

Build two

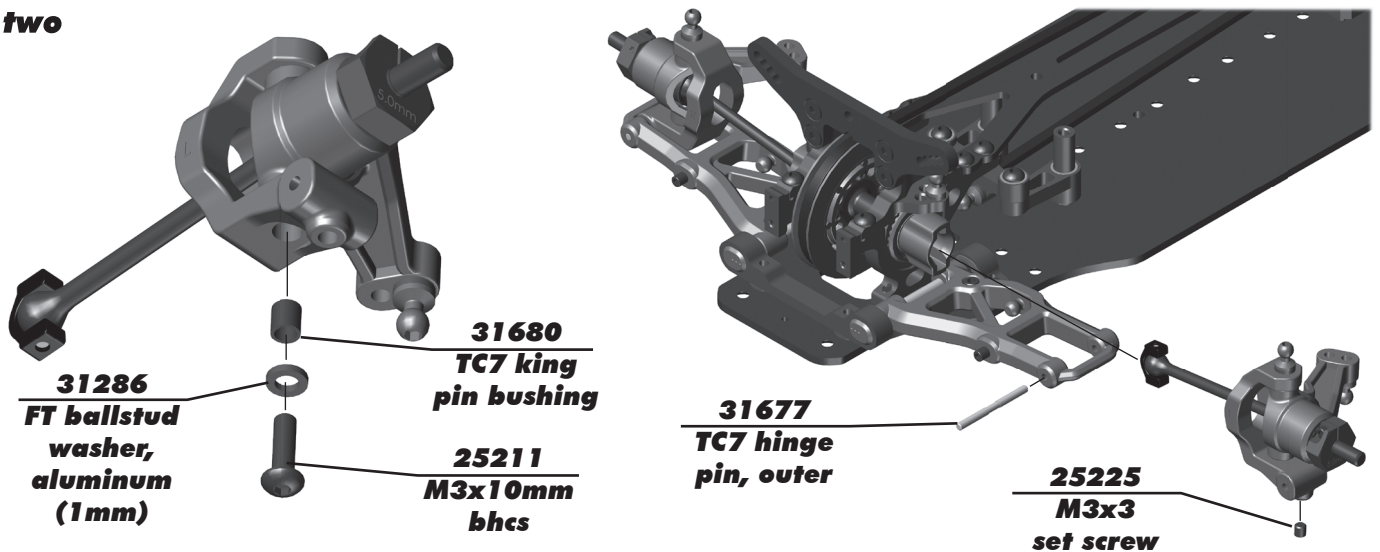

:: Caster Blocks and Hubs Build - Bag 14, 15, & 16 - Step 5

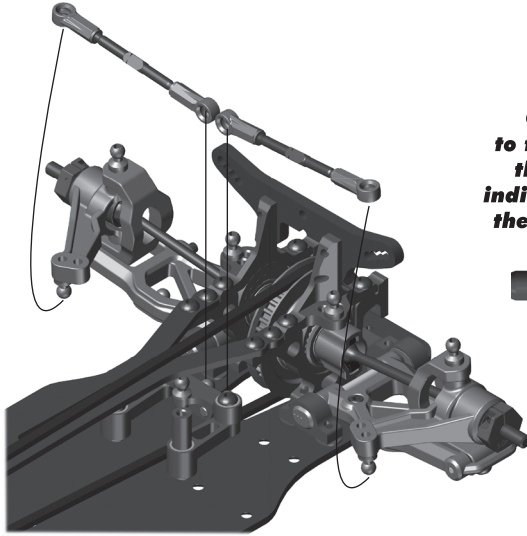

!
 Orient the notch to the left throughout the car. The notch indicates which end has the left hand threads!

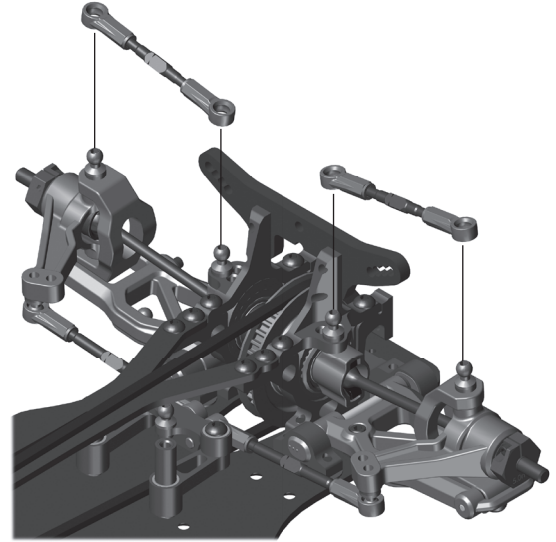
:: Caster Blocks and Hubs Build - Bag 14, 15, & 16 - Step 6



It is important that the turnbuckle eyelets move freely once snapped on to the ballstud. If the fit is too tight, the car handling will be inconsistent. To check, grab turnbuckle eyelet with fingers and rotate the cup. If there is resistance, lightly squeeze ball cup with needle nose pliers as shown and test again. It is important that the ball cup be snapped onto the ballstud before squeezing with needle nose pliers. Be sure to check and adjust the fit for each ball cup that is installed.

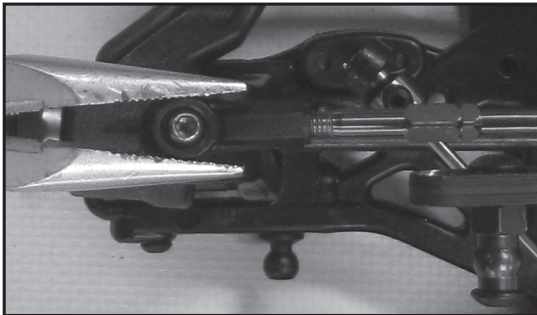

Use a 1.5mm hex tool tip to poke through any left over flashing (extra thin piece of plastic) in the hinge pin set screw hole on the rear hubs.



:: Caster Blocks and Hubs Build - Bag 14, 15, & 16 - Step 7

Build left and right sides

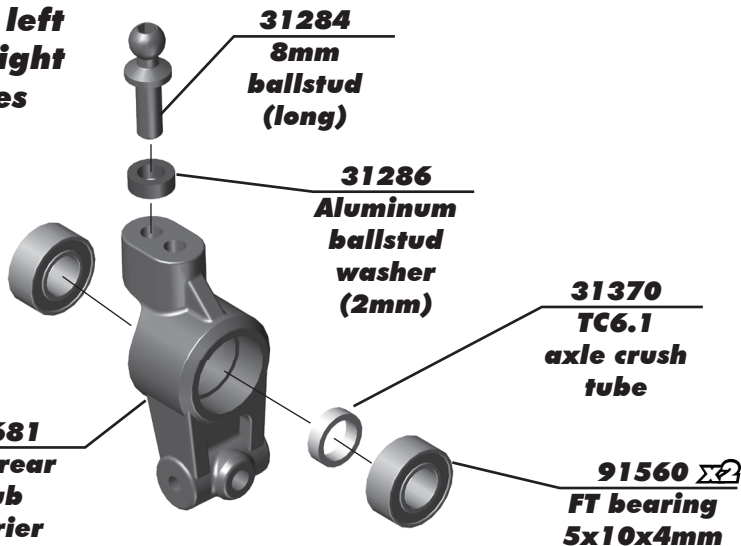

Build left and right sides

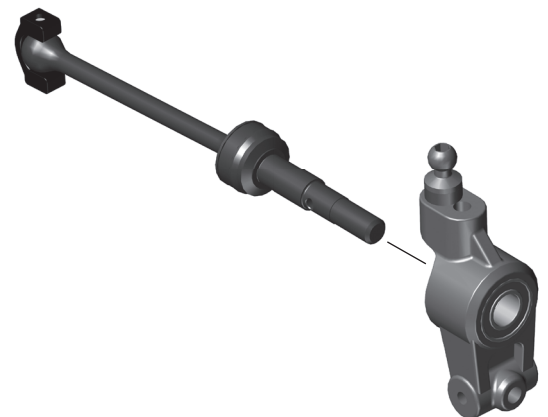

:: Caster Blocks and Hubs Build - Bag 14, 15, & 16 - Step 8

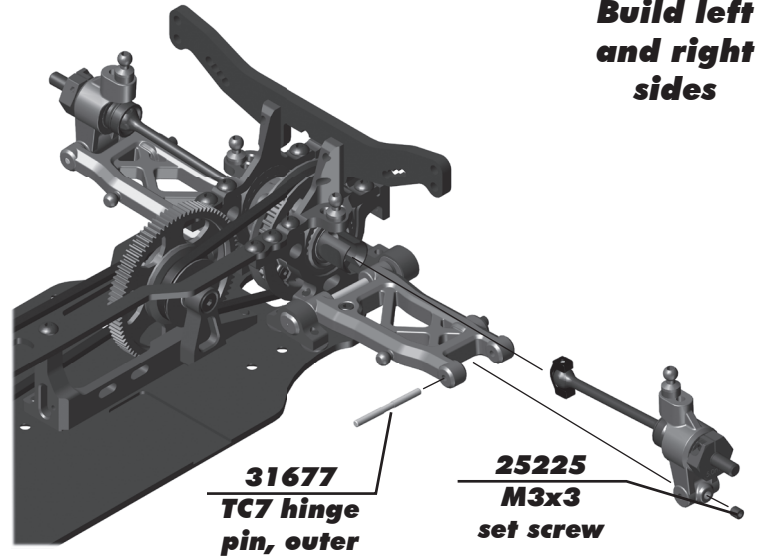
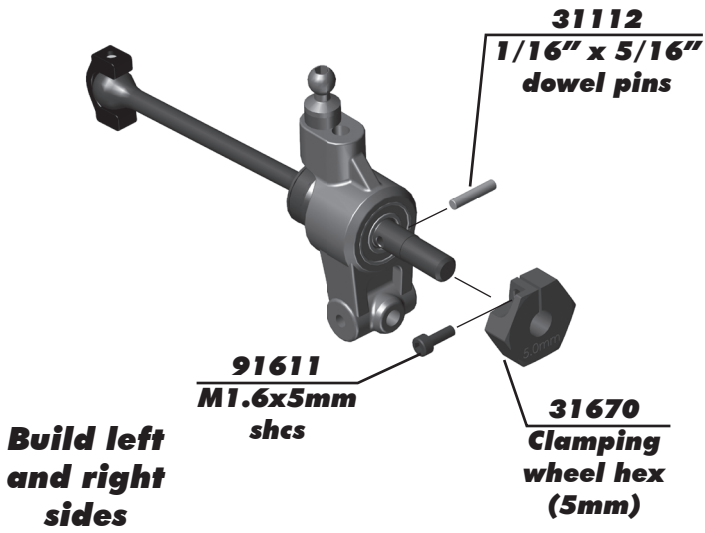

:: Caster Blocks and Hubs Build - Bag 14, 15, & 16 - Step 9

!
Orient the notch
to the left throughout
the car. The notch
indicates which end has
the left hand threads!

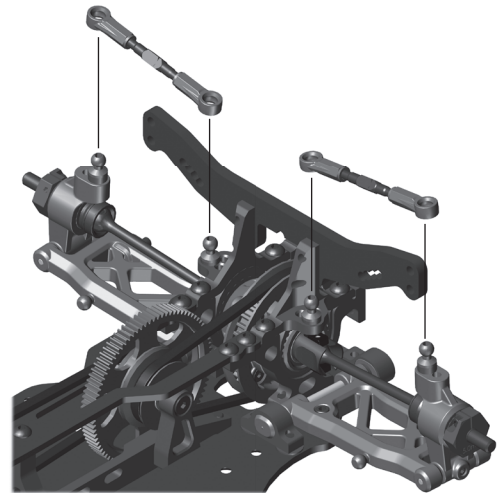

:: Bumper, Anti-Roll Bar, and Electronics Build - Bag 17 & 18 - Step 1

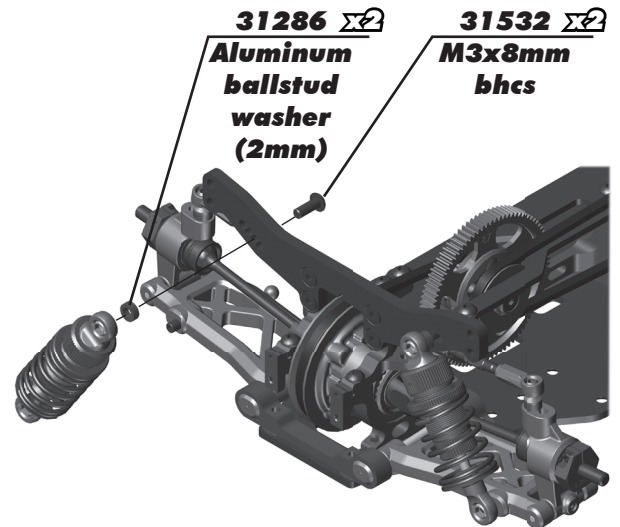
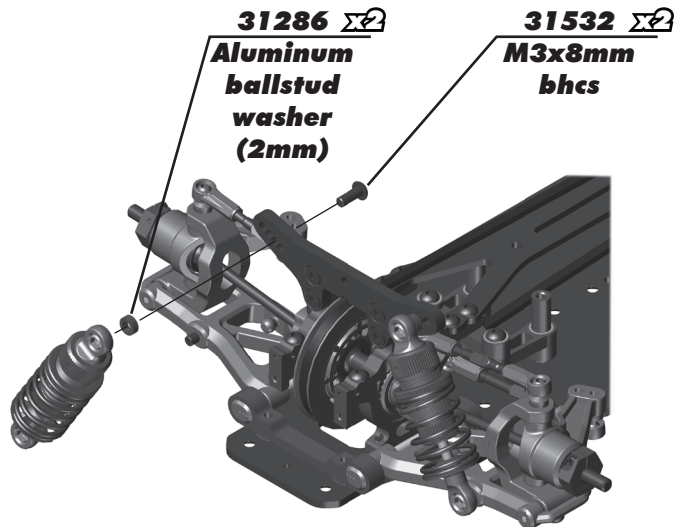

:: Bumper, Anti-Roll Bar, and Electronics Build - Bag 17 & 18 - Step 2

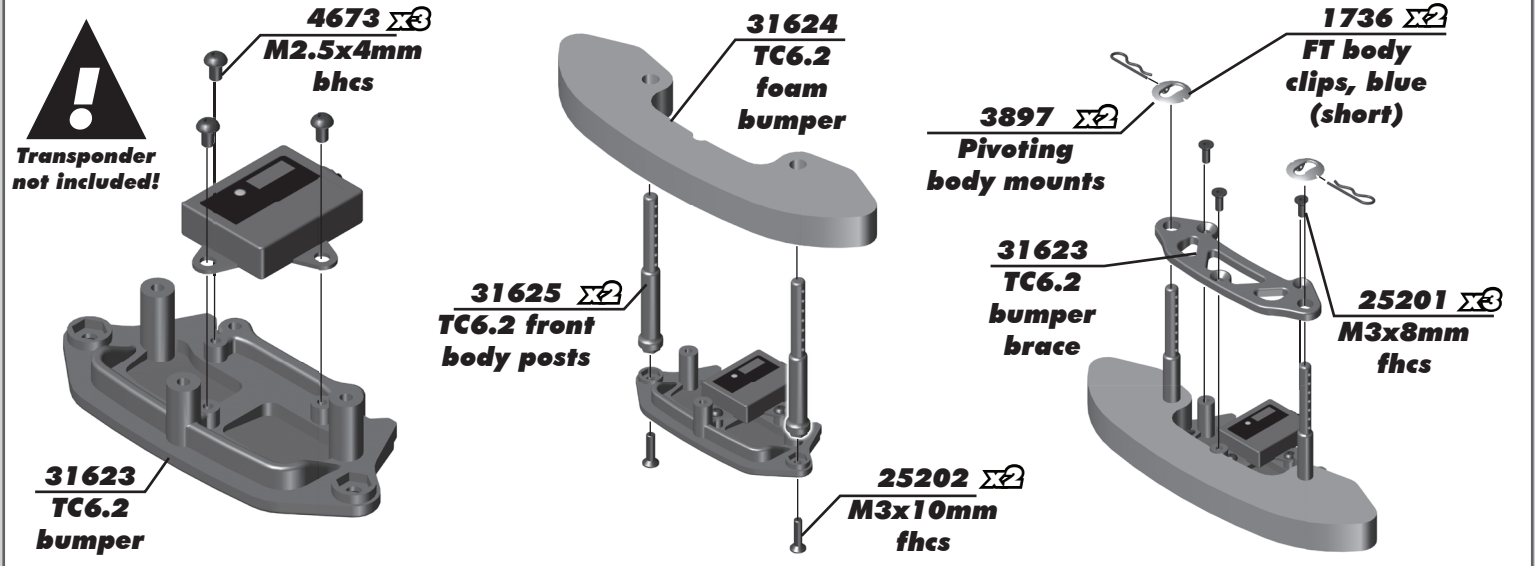

:: Bumper, Anti-Roll Bar, and Electronics Build - Bag 17 & 18 - Step 3

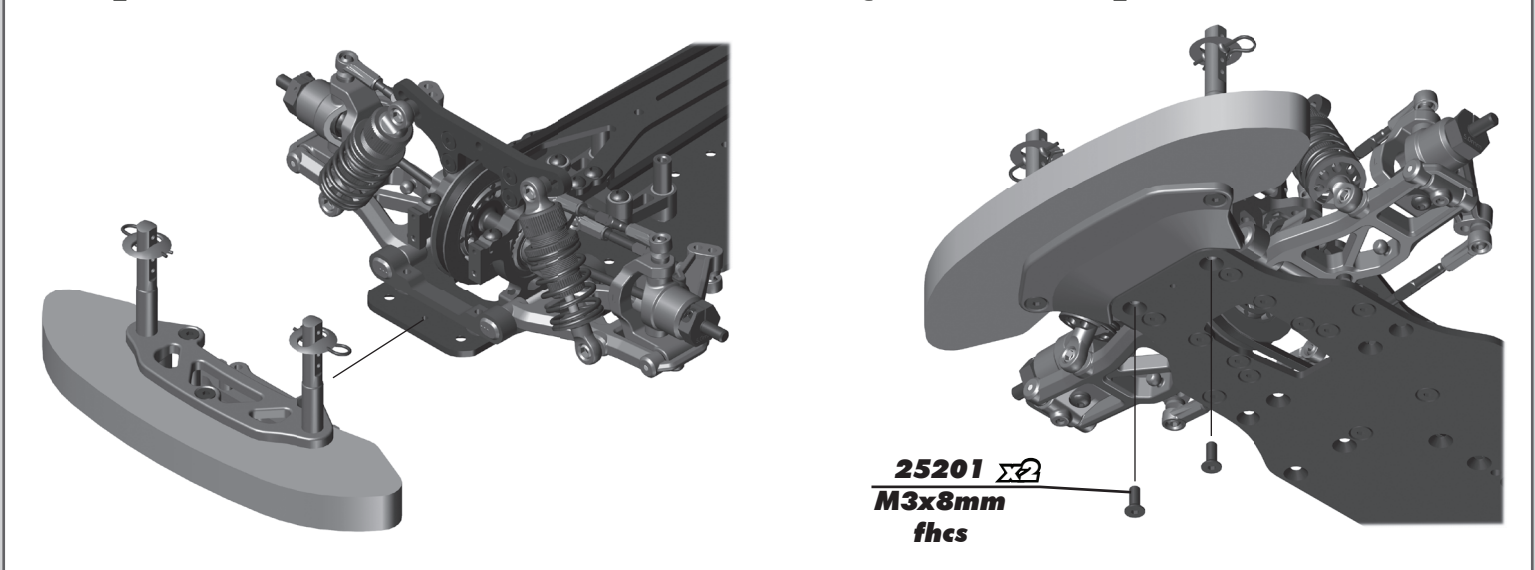

:: Bumper, Anti-Roll Bar, and Electronics Build - Bag 17 & 18 - Step 4

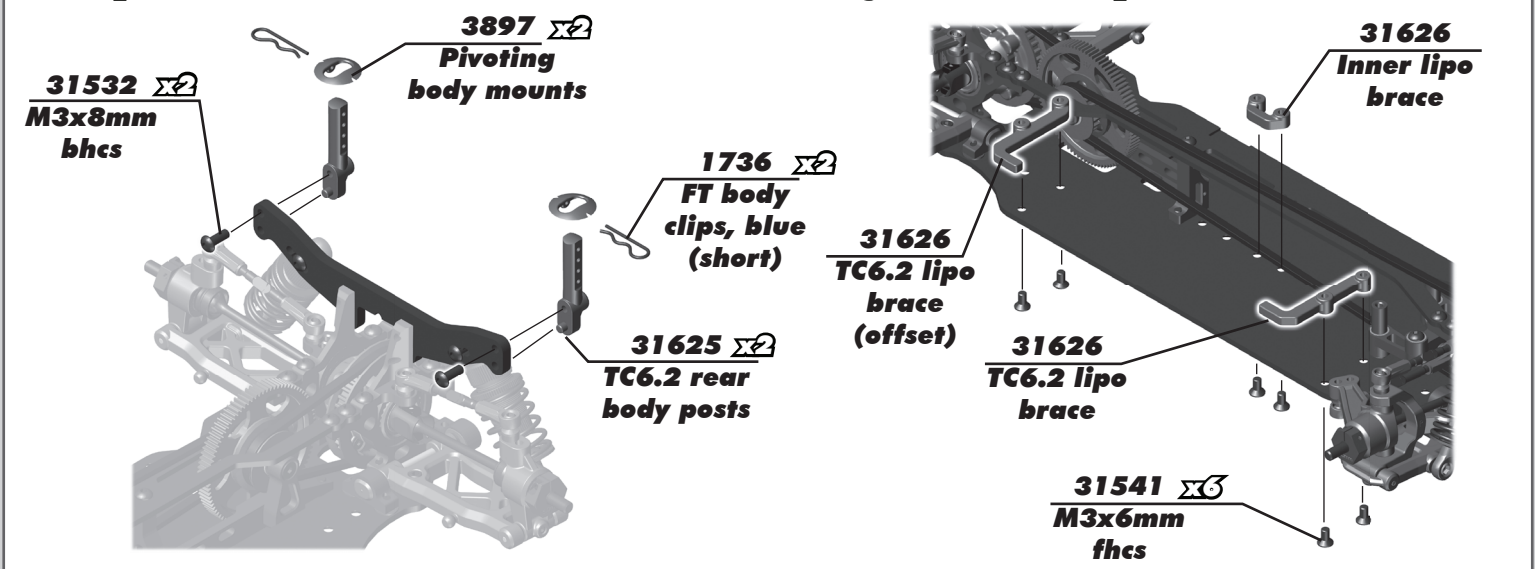

:: Bumper, Anti-Roll Bar, and Electronics Build - Bag 17 & 18 - Step 5

31701 TC7 anti-roll bar eyelet

31701 TC7 anti-roll bar coupler

31058 Anti roll bar ballstud

31305 Turnbuckle eyelet

31500 M3x2.5mm set screw

31703 TC7 Front anti-roll bar, 1.4mm (blue)

31707 TC7 Rear anti-roll bar, 1.2mm (white)

31701 TC7 anti-roll bar retainer

Anti Roll Bar Link Adjustment
9.5mm

Anti Roll Bar Color/Size Chart	
Green	1.1mm
White	1.2mm
Gray	1.3mm
Blue	1.4mm
Yellow	1.5mm

Build four anti-roll bar mounts

Shrink the colored heat shrink tubing to the anti roll bar!

:: Bumper, Anti-Roll Bar, and Electronics Build - Bag 17 & 18 - Step 6

31500 M3x2.5mm set screw

25225 x2 M3x3mm set screw

31511 x2 M2x5mm shcs

31701 x2 TC7 anti-roll bar mount

:: Bumper, Anti-Roll Bar, and Electronics Build - Bag 17 & 18 - Step 7

31500 M3x2.5mm set screw

25225 x2 M3x3mm set screw

31511 x2 M2x5mm shcs

31701 x2 TC7 anti-roll bar mount

:: Bumper, Anti-Roll Bar, and Electronics Build - Bag 17 & 18 - Step 8

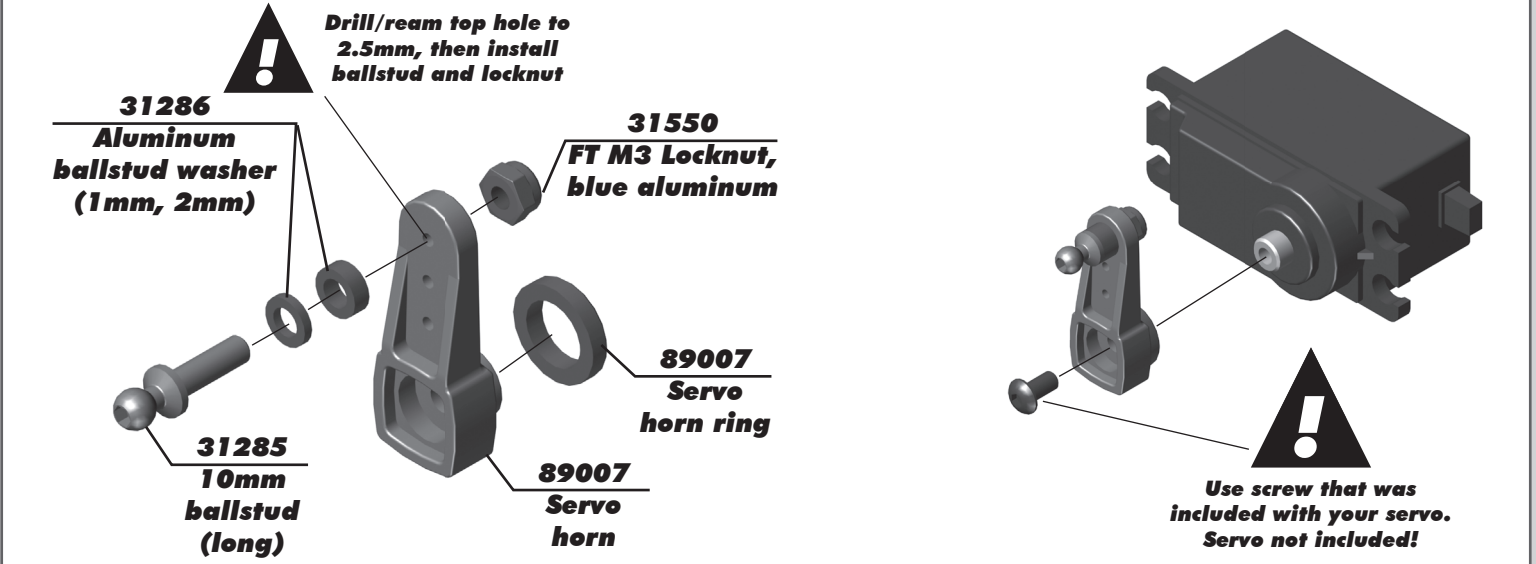

:: Bumper, Anti-Roll Bar, and Electronics Build - Bag 17 & 18 - Step 9

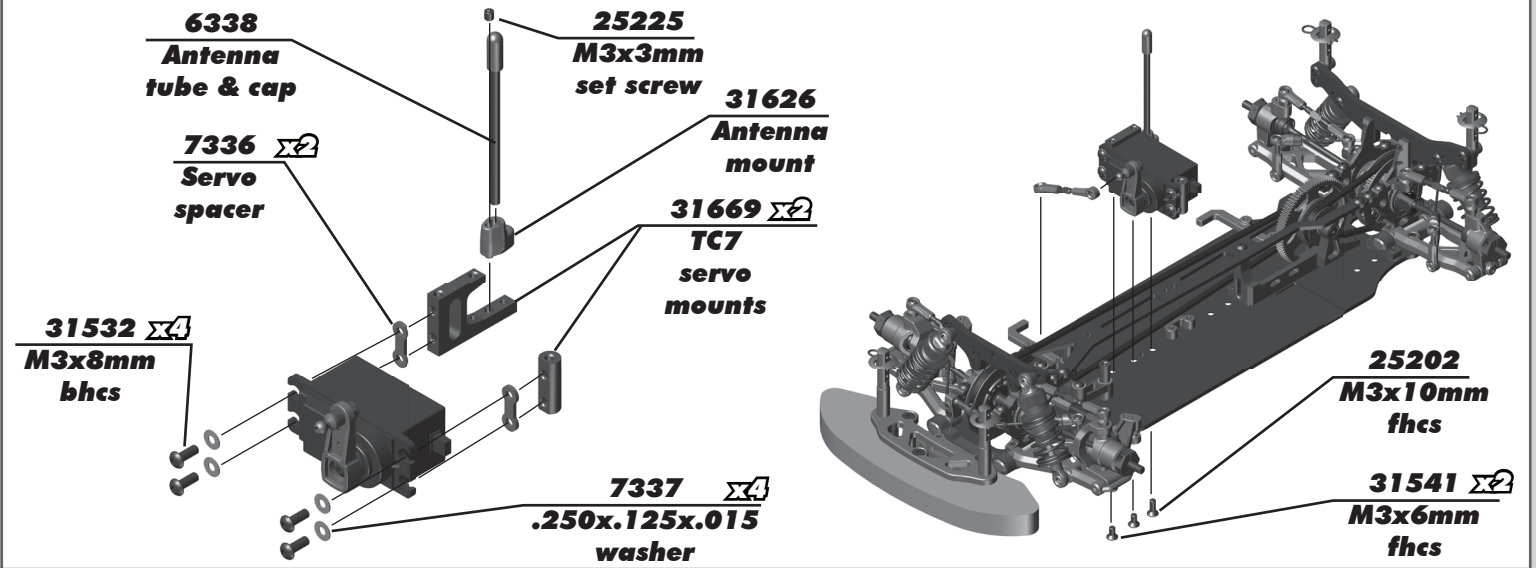

:: Bumper, Anti-Roll Bar, and Electronics Build - Bag 17 & 18 - Step 10

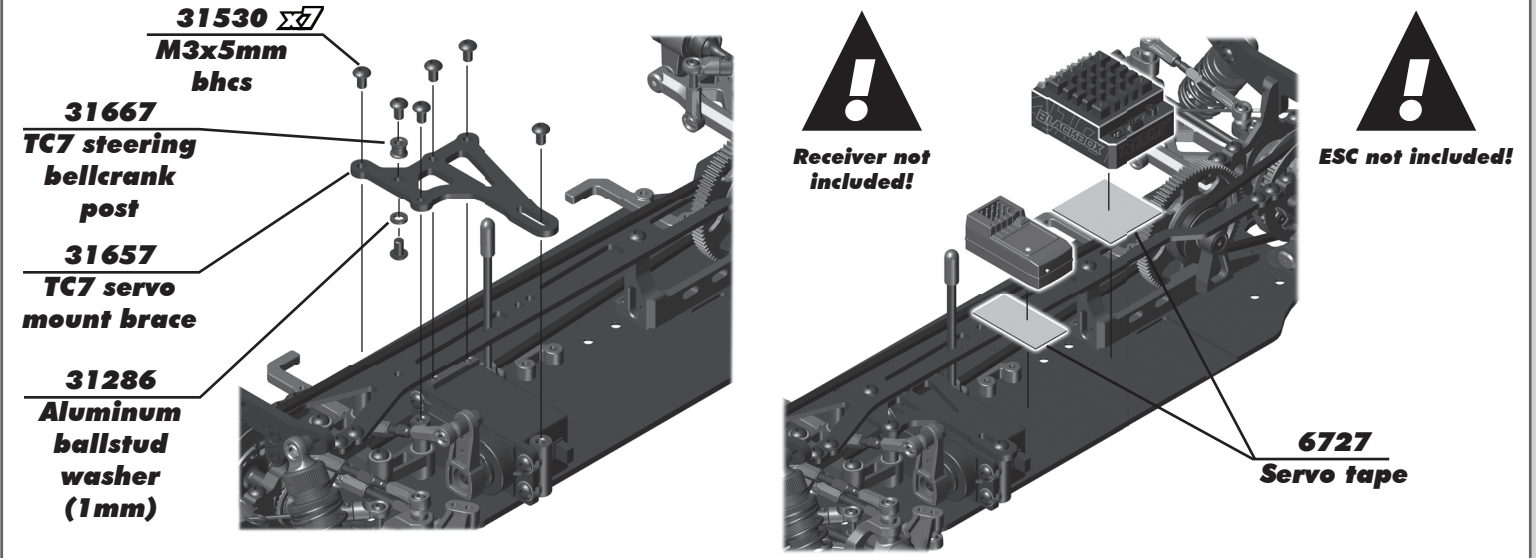

:: Bumper, Anti-Roll Bar, and Electronics Build - Bag 17 & 18 - Step 11

Gearing will depend on the motor and track size.
Gear chart on page 27.
Motor, pinion gear, and set screw are not included!

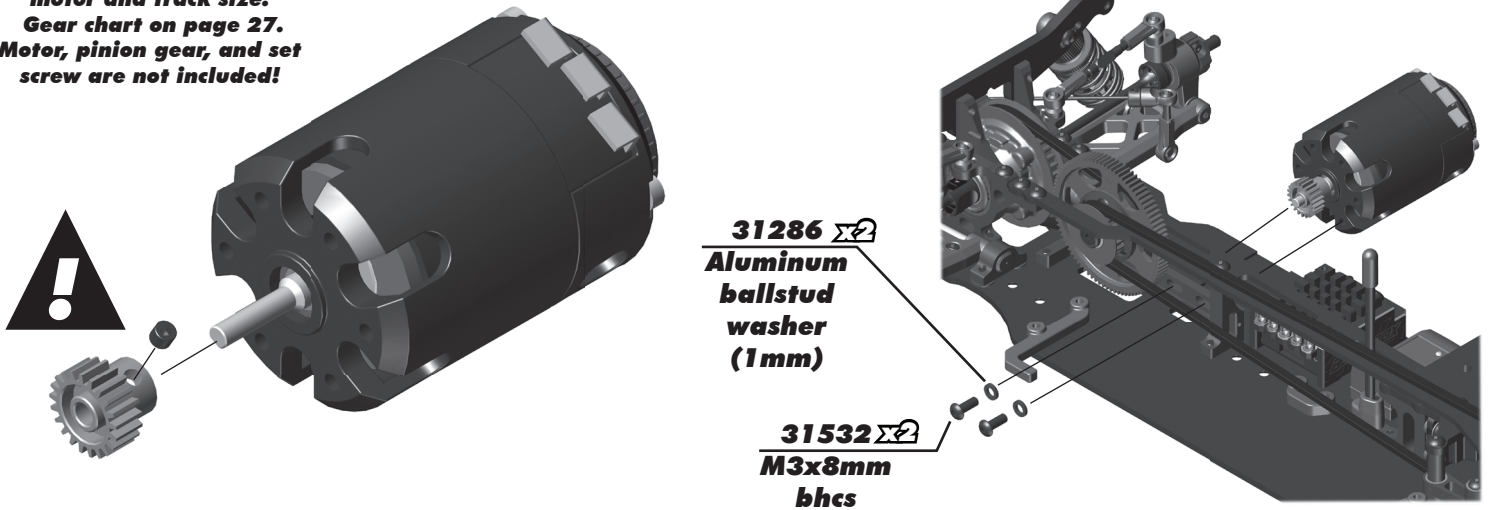

:: Bumper, Anti-Roll Bar, and Electronics Build - Bag 17 & 18 - Step 12

Use strapping tape to secure battery into chassis. Wrap the tape around the #31626 LiPo brace on back onto itself. Strapping tape not included!

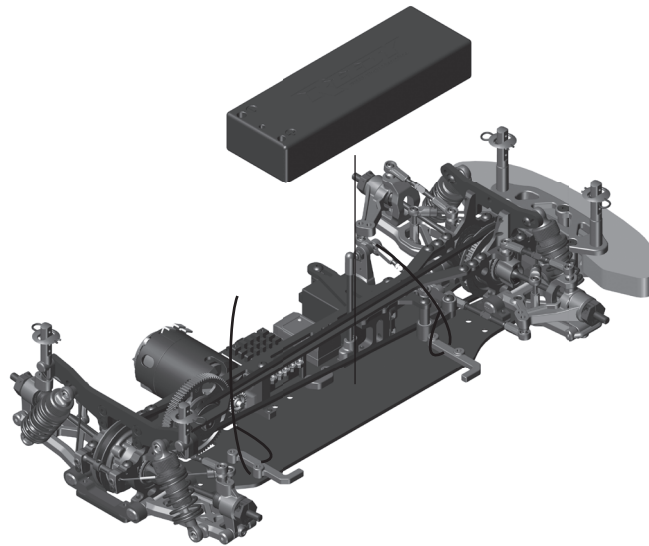

Battery and strapping tape not included!

:: Bumper, Anti-Roll Bar, and Electronics Build - Bag 17 & 18 - Step 13

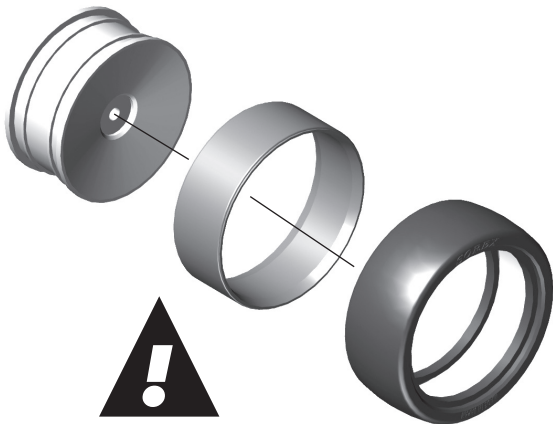

Wheels, tires, and inserts not included!

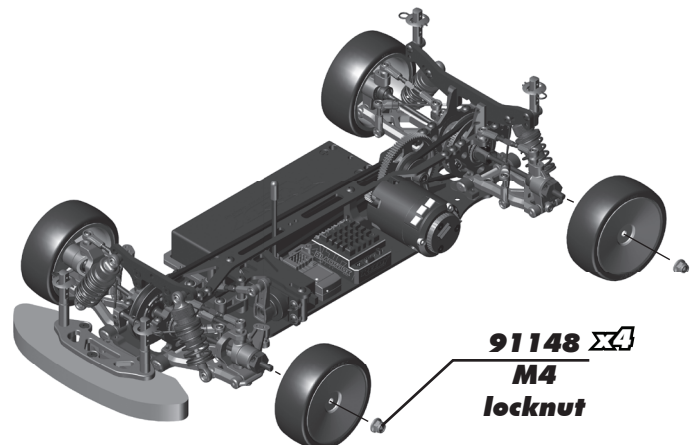

:: Tuning Tips

Tips for Beginners:

Before making any changes to the standard setup, make sure you can get around the track without crashing. Changes to your car will not be beneficial if you can't stay on the track. Your goal is consistent laps.

Once you can get around the track consistently, start tuning your car. Make only ONE adjustment at a time, testing it before making another change. If the result of your adjustment is a faster lap, mark the change on the included setup sheet (make additional copies of the sheet before writing on it). If your adjustment results in a slower lap, revert back to the previous setup and try another change.

When you are satisfied with your car, fill in the setup sheet thoroughly and file it away. Use this as a guide for future track days or conditions.

Ride Height:

The standard starting point for ride height is 5.0mm (keep in mind that your local track may have minimum ride height requirements). You can slightly raise the rear relative to the front to give the car more steering. Raise the car slightly for tracks with large bumps.

Battery Placement:

For most cases, run the battery in the standard forward position. Typically this will be the most stable and easiest to drive. Try moving the battery back if you encounter a low traction surface by switching LiPo braces front to back.

Wheelbase:

Lengthening the front will reduce steering, shortening the front will increase steering. Shortening the rear will increase rear grip, lengthening the rear will decrease rear traction.

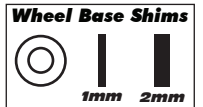

Rear Toe-In:

The TC7 allows rear toe adjustments in two positions: inner hinge pin, and outer hinge pin at the rear hub. In general, decreasing rear toe-in will decrease rear traction and increase corner speed.

Rear toe-in can be adjusted by 0.5° increments at the inner hinge pin with supplied arm mount inserts (see chart to right). Standard toe-in angle for inner hinge pin when using same insert front and rear is 3°. Standard insert used is 1 dot.

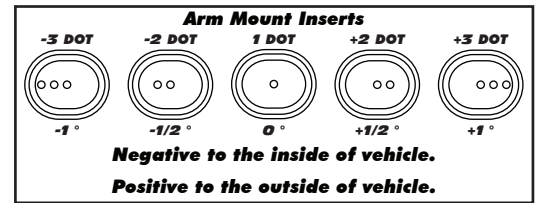

Ackermann & Steering Rate:

Ackermann refers to the relative angle difference between the front wheels as they are turned to steer the car. The outside wheel will turn less than the inside wheel in most conditions. Settings with more Ackermann will have a bigger difference in wheel angle, causing the outside wheel to turn less. Likewise, settings with less Ackermann will cause the outside wheel to turn more.

Increasing the Ackermann will smooth out the steering and is used most often on high traction surfaces such as carpet. This is a result of the reduced outside wheel angle. Settings with reduced Ackermann will help to increase corner entry steering, and are typically used when running a spool in the front.

The chart to the right lists the different Ackermann options.

Steering Block Position	Steering Rack Shims	Ackermann
B	2mm	Less Ackermann
B	1mm	STD
B	0mm	More Ackermann
A	2mm	
A	1mm	
A	0mm	

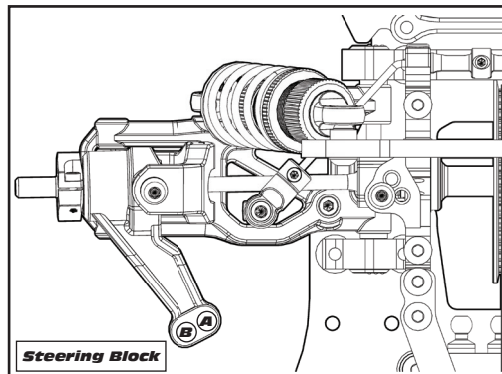

:: Tuning Tips

Drop:

The standard settings of 6mm front and 5mm rear will work best in most cases. Droop is measured just underneath the outer hinge pin as shown in the photos to the right.

On bumpy or low grip surfaces, increase the droop (going to a lower number on the droop gauge), this will help increase traction and consistency.

Droop adjustments of 0.5mm to 1mm can be very effective on the track!

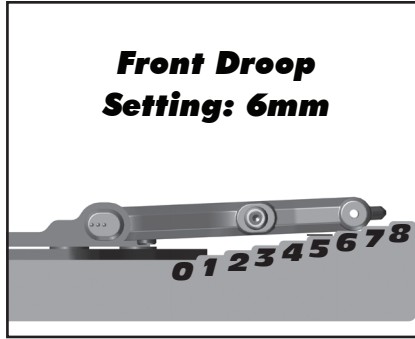

**Front Droop
Setting: 6mm**

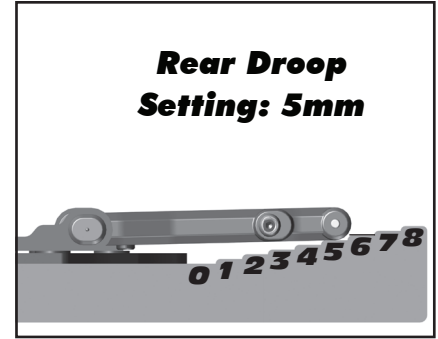

**Rear Droop
Setting: 5mm**

Camber Link Position:

The camber link is used to set static camber at ride height, but it is also an effective setting to adjust roll center height and camber gain. The TC7 has three optimized length positions at the front, and six at the rear, for a wide range of camber gain adjustments. All camber link mounting positions use vertical ballstuds that can be shimmed for precise roll center height adjustments.

Longer links will produce less camber gain, stiffening that particular end of the car in roll. These are particularly effective on large tracks with big sweeping corners. Shorter links will give more camber gain, softening that end of the car in roll. This will make the car more aggressive, and is a good setting for smaller indoor tracks with high grip levels.

The angle of the camber link will make fine adjustments to the roll center height. Typically the camber link will be no more than parallel to the suspension arm with the inboard side of the link lower than the outboard side. As the inboard side of the camber link is moved down, the roll center goes up, stiffening that end of the car. Camber link angle is a good adjustment to help fine tune the balance of the car to the track by setting the front and rear at slightly different angles.

Arm Mount Position:

The TC7's arm mount system allows for maximum adjustability for all track and racing conditions. Independent inner and outer arm mounts with interchangeable inserts provide multiple pin configurations... flat, or with angle, to give a host of kickup/tow and pin width options.

Use the TC7's included arm mount inserts to adjust pin width and angle. The arm mount inserts are indicated one, two, and three with the corresponding amount of dots on their exposed face. Each insert will index the hinge pin by 1/2 degree (or 0.43mm). Standard pin angle is achieved when using the same insert in both the inner and outer mounts. Rear hinge pin angle is 3° when using the same insert in both inner and outer mounts.

The chart to the right shows the pin angle change for the right rear pin when using a 1 dot insert in the inner arm mount.

Pin width can also be adjusted by changing the inserts in the inner and outer mounts by an equal amount. The standard pin width for the TC7 uses -3 dot inserts for the front and 1 dot inserts for the rear. This is best suited for rubber tire racing.

The TC7's independent inner and outer arm mount system also allows for roll center height adjustments as well as options for anti-dive/kick-up and anti-squat/pro-squat hinge pin angles. Precise adjustments can be made by changing the shim thickness between the arm mounts and chassis.

The standard roll center height uses 0.5mm shims on all mounts. This produces a relatively low roll center with more chassis roll on the corners... typically good for lower grip conditions such as rubber tires on asphalt. If the grip level is high, try raising the roll center by using thicker shims between the mounts and chassis.

Anti-dive/kick-up and anti-squat/pro-squat angles can be adjusted by varying the amount of shims under the inner and outer mounts. A 0.5mm difference will produce an angle of about 1/2 degree. The following sections briefly describe front and rear pin angles and their effect on the track.

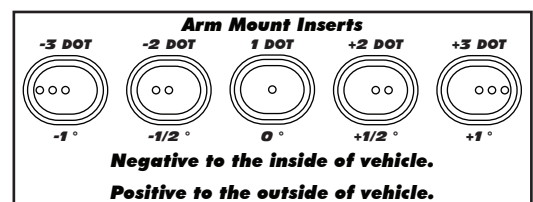
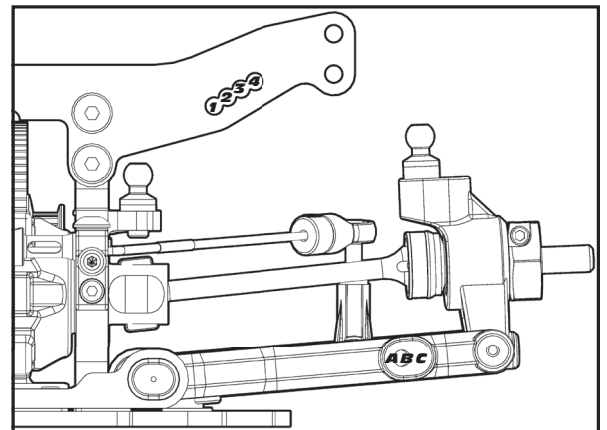

:: Tuning Tips

Anti-Dive (front):

Anti-dive is a front arm angle where the rear mount is higher than the front mount. Adding anti-dive reduces weight transfer to the front on deceleration entering corners. It also reduces caster at the wheel.

Kick-Up (front):

Kick-up describes the angle of the front suspension arm, where the front mount is higher than the rear mount. Increasing kick-up will give more entry steering, as well as increasing caster at the wheel.

Anti-Squat (rear):

Anti-Squat describes a rear arm angle where the front mount is higher than the rear mount. Increasing anti-squat will make the rear suspension stiffer. It tends to give the car more entry steering and reduce rearward weight transfer on power.

Pro-Squat (rear):

Pro-squat is a rear arm angle where the rear mount is higher than the front mount. Running Pro-Squat will increase rearward weight transfer on power.

Anti-Roll Bar:

Anti-roll bars are only effective during roll (when the chassis leans from side to side when cornering). Because of this they isolate a change in the suspensions spring rate in the corners only, and can be a very useful tuning option.

Anti-roll bars stiffen the spring rate of the suspension during roll movements when cornering. The larger the roll bar wire, the stiffer the spring rate will be in roll. The chart on the right shows the available anti-roll bar sizes (as well as their corresponding colors) from the softest on the top, to the stiffest on the bottom.

Anti Roll Bar Color/Size Chart	
Green	1.1mm
White	1.2mm
Gray	1.3mm
Blue	1.4mm
Yellow	1.5mm

The standard setup with a blue front anti-roll bar (1.4mm) and a white rear anti-roll bar (1.2mm), is a balanced starting point. Changing the size of the front or rear anti-roll bars can help to make the chassis more consistent through the corner. Decreasing the size of the front anti-roll bars will help to increase mid-corner steering, but will tend to be less stable in sweepers. This is a typical setup for smaller tracks with tighter turns. Increasing the size of the front anti-roll bars will give more stability in the sweepers, and is better for larger tracks with high speed corners. Increasing the size of the rear anti-roll bars will help add stability into and through the corner in high traction conditions, but can make the car inconsistent in low traction, or bumpy, surfaces.

Belt Tension:

When altering the differential height, you will need to adjust the tension of the belt. The following chart shows suggested starting positions.

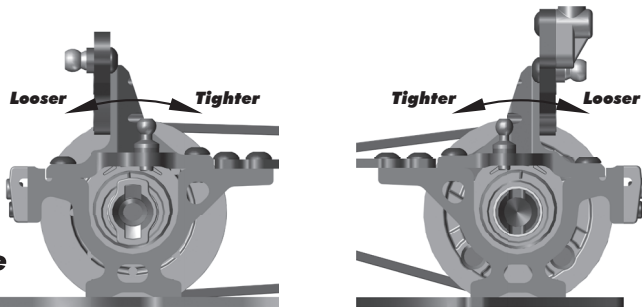

Cam Position		Belt Tension Number
Mid-Low	Mid-High	
Low	High	

View from left side of car

Front	Height	Pos.
	High	31
	Mid-High	28
	Mid	8
Low	5	

Rear	Height	Pos.
	High	18
	Mid-High	20
	Mid	7
Low	9	

Note! Charts show left side cam positions from the left side of the car. Match right side cam position to left side cam position.

Motor Gearing:

The gear charts on the following page show final drive ratio numbers for the TC7. Refer to motor manufacturer's suggested gear ratio for starting point. You may need to adjust the gearing according to your track size.

The following formula's can also be helpful in determining final drive ratios and pinion size.

$$TC7 \text{ Internal Ratio} = 2.0$$

$$\text{Final Drive Ratio} = \frac{\text{\# of Teeth Spur} \times \text{(Internal Ratio)}}{\text{\# of Teeth on Pinion}}$$

$$\text{\# of Teeth on Pinion} = \frac{\text{\# of Teeth on Spur} \times \text{(Internal Ratio)}}{\text{Final Drive Ratio}}$$

:: Gear Chart 48 Pitch



Blank spaces in the gear charts designates a gear ratio that will not fit in the vehicle. Gear fitment will also depend on the motor brand.

		Spur Gear Teeth (48 Pitch)											Advanced Timing Stock Brushes and Modified Brushes	
Pinion teeth (48 Pitch)		77	78	79	80	81	82	83	84	85	86	87		
	15	--	--	--	--	--	--	--	--	--	--	--		11.60
	16	--	--	--	--	--	--	--	--	--	10.75	10.88		
	17	--	--	--	--	--	--	--	--	10.00	10.12	10.24		
	18	--	--	--	--	--	--	--	9.33	9.44	9.56	9.67		
	19	--	--	--	--	--	--	8.74	8.84	8.95	9.05	9.16		
	20	--	--	--	--	--	8.20	8.30	8.40	8.50	8.60	8.70		
	21	--	--	--	--	7.71	7.81	7.90	8.00	8.10	8.19	8.29		
	22	--	--	--	7.27	7.36	7.45	7.55	7.64	7.73	7.82	7.91		
	23	--	--	6.87	6.96	7.04	7.13	7.22	7.30	7.39	7.48	7.57		
	24	--	6.50	6.58	6.67	6.75	6.83	6.92	7.00	7.08	7.17	7.25		
	25	6.16	6.24	6.32	6.40	6.48	6.56	6.64	6.72	6.80	6.88	6.96		
	26	5.92	6.00	6.08	6.15	6.23	6.31	6.38	6.46	6.54	6.62	6.69		
27	5.70	5.78	5.85	5.93	6.00	6.07	6.15	6.22	6.30	6.37	6.44			
28	5.50	5.57	5.64	5.71	5.79	5.86	5.93	6.00	6.07	6.14	6.21			

		Spur Gear Teeth (48 Pitch)											Non-Timing Stock Brushes	
Pinion teeth (48 Pitch)		66	67	68	69	70	71	72	73	74	75	76		
	36	3.67	3.72	3.78	3.83	3.89	3.94	4.00	4.06	4.11	4.17	4.22		
	37	3.57	3.62	3.68	3.73	3.78	3.84	3.89	3.95	4.00	4.05	4.11		
	38	3.47	3.53	3.58	3.63	3.68	3.74	3.79	3.84	3.89	3.95	4.00		
	39	3.38	3.44	3.49	3.54	3.59	3.64	3.69	3.74	3.79	3.85	3.90		
	40	3.30	3.35	3.40	3.45	3.50	3.55	3.60	3.65	3.70	3.75	--		
	41	3.22	3.27	3.32	3.37	3.41	3.46	3.51	3.56	3.61	--	--		
	42	3.14	3.19	3.24	3.29	3.33	3.38	3.43	3.48	--	--	--		
	43	3.07	3.12	3.16	3.21	3.26	3.30	3.35	--	--	--	--		
	44	3.00	3.05	3.09	3.14	3.18	3.23	--	--	--	--	--		

:: Gear Chart 64 Pitch

		Spur Gear Teeth (64 Pitch)														Advanced Timing Stock Brushes and Modified Brushes	
Pinion teeth (64 Pitch)		102	103	104	105	106	107	108	109	110	111	112	113	114	115		
	20	--	--	--	--	--	--	--	--	--	--	--	--	--	--		11.50
	21	--	--	--	--	--	--	--	--	--	--	--	--	--	10.86		10.95
	22	--	--	--	--	--	--	--	--	--	--	--	10.27	10.36	10.45		
	23	--	--	--	--	--	--	--	--	--	--	--	9.83	9.91	10.00		
	24	--	--	--	--	--	--	--	--	--	--	9.33	9.42	9.50	9.58		
	25	--	--	--	--	--	--	--	--	--	8.88	8.96	9.04	9.12	9.20		
	26	--	--	--	--	--	--	--	8.46	8.54	8.62	8.69	8.77	8.85			
	27	--	--	--	--	--	--	8.07	8.15	8.22	8.30	8.37	8.44	8.52			
	28	--	--	--	--	--	7.71	7.79	7.86	7.93	8.00	8.07	8.14	8.21			
	29	--	--	--	--	7.38	7.45	7.52	7.59	7.66	7.72	7.79	7.86	7.93			
	30	--	--	--	7.07	7.13	7.20	7.27	7.33	7.40	7.47	7.53	7.60	7.67			
	31	--	--	6.77	6.84	6.90	6.97	7.03	7.10	7.16	7.23	7.29	7.35	7.42			
	32	--	6.50	6.56	6.63	6.69	6.75	6.81	6.88	6.94	7.00	7.06	7.13	7.19			
	33	--	6.24	6.30	6.36	6.42	6.48	6.55	6.61	6.67	6.73	6.79	6.85	6.91	6.97		
	34	6.00	6.06	6.12	6.18	6.24	6.29	6.35	6.41	6.47	6.53	6.59	6.65	6.71	6.76		
	35	5.83	5.89	5.94	6.00	6.06	6.11	6.17	6.23	6.29	6.34	6.40	6.46	6.51	6.57		
	36	5.67	5.72	5.78	5.83	5.89	5.94	6.00	6.06	6.11	6.17	6.22	6.28	6.33	6.39		
	37	5.51	5.57	5.62	5.68	5.73	5.78	5.84	5.89	5.95	6.00	6.05	6.11	6.16	6.22		
	38	5.37	5.42	5.47	5.53	5.58	5.63	5.68	5.74	5.79	5.84	5.89	5.95	6.00	6.05		
39	5.23	5.28	5.33	5.38	5.44	5.49	5.54	5.59	5.64	5.69	5.74	5.79	5.85	5.90			

		Spur Gear Teeth (64 Pitch)														Non-Timing Stock Brushes	
Pinion teeth (64 Pitch)		88	89	90	91	92	93	94	95	96	97	98	99	100	101		
	47	3.74	3.79	3.83	3.87	3.91	3.96	4.00	4.04	4.09	4.13	4.17	4.21	4.26	4.30		
	48	3.67	3.71	3.75	3.79	3.83	3.88	3.92	3.96	4.00	4.04	4.08	4.13	4.17	4.21		
	49	3.59	3.63	3.67	3.71	3.76	3.80	3.84	3.88	3.92	3.96	4.00	4.04	4.08	4.12		
	50	3.52	3.56	3.60	3.64	3.68	3.72	3.76	3.80	3.84	3.88	3.92	3.96	4.00	4.04		
	51	3.45	3.49	3.53	3.57	3.61	3.65	3.69	3.73	3.76	3.80	3.84	3.88	3.92	3.96		
	52	3.38	3.42	3.46	3.50	3.54	3.58	3.62	3.65	3.69	3.73	3.77	3.81	3.85	3.88		
	53	3.32	3.36	3.40	3.43	3.47	3.51	3.55	3.58	3.62	3.66	3.70	3.74	3.77	3.81		
	54	3.26	3.30	3.33	3.37	3.41	3.44	3.48	3.52	3.56	3.59	3.63	3.67	3.70	--		
	55	3.20	3.24	3.27	3.31	3.35	3.38	3.42	3.45	3.49	3.53	3.56	3.60	--	--		
	56	3.14	3.18	3.21	3.25	3.29	3.32	3.36	3.39	3.43	3.46	3.50	--	--	--		
	57	3.09	3.12	3.16	3.19	3.23	3.26	3.30	3.33	3.37	3.40	--	--	--	--		
	58	3.03	3.07	3.10	3.14	3.17	3.21	3.24	3.28	3.31	--	--	--	--	--		

:: Shocks

4637	FT Pivot Balls	8
5407	Red O-Rings	8
21139	Washers, M2.6 x 6	20
31327	VCS3 Shock Bottom Caps	2
31510	M2 x 4mm BHCS	6
31684	TC7 Shock Kit	1
<i>(Fox Kashima Coat), builds 2</i>		
31687	TC7 Shock Body (Fox Kashima Coat)	2
31688	TC7 Shock Shaft	2
31689	TC7 Shock Piston (3x1.1)	4
31693	TC7 Shock Rebuild Kit	1
31696	TC7 Shock Cap Retainer	4
31697	TC7 Shock Collar & O-Ring	4
31698	TC7 Shock Spring Cup	4
31700	TC7 Shock Eyelet Set	1

:: Springs

31715	TC Spring (White), 13.8lbs	Pr.
31716	TC Spring, (Gray), 15.0lbs	Pr.
31717	TC Spring, (Blue), 15.9lbs - Kit	Pr.
31718	TC Spring, (Yellow), 16.8lbs	Pr.

:: Shock Fluid

5420	10 Weight Silicone Shock Fluid	2oz.
5421	20 Weight Silicone Shock Fluid	2oz.
5422	30 Weight Silicone Shock Fluid	2oz.
5423	40 Weight Silicone Shock Fluid	2oz.
5424	22.5 Weight Silicone Shock Fluid	2oz.
5425	80 Weight Silicone Shock Fluid	2oz.
5426	27.5 Weight Silicone Shock Fluid	2oz.
5427	15 Weight Silicone Shock Fluid	2oz.
5428	25 Weight Silicone Shock Fluid	2oz.
5429	35 Weight Silicone Shock Fluid	2oz.
5430	45 Weight Silicone Shock Fluid	2oz.
5431	55 Weight Silicone Shock Fluid	2oz.
5432	32.5 Weight Silicone Shock Fluid	2oz.
5433	37.5 Weight Silicone Shock Fluid	2oz.
5434	42.5 Weight Silicone Shock Fluid	2oz.
5435	50 Weight Silicone Shock Fluid	2oz.
5436	60 Weight Silicone Shock Fluid	2oz.
5437	70 Weight Silicone Shock Fluid	2oz.
5438	47.5 Weight Silicone Shock Fluid	2oz.

:: CVA's

31237	CVA Pin Retaining Clip	2
31238	CVA Bone Blade	8
31366	TC6.1 CVA Kit	1
31367	TC6.1 CVA Rebuild Kit	1
31368	TC6.1 CVA Bone	Pr.
31369	TC6.1 Stub Axle	Pr.
31500	M3 x 2.5mm Set Screw	6

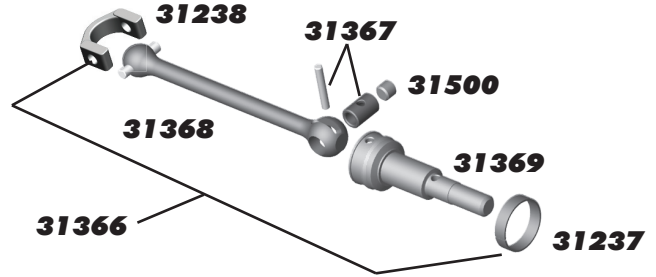

:: Anti-Roll Bars

25225	M3 x 3mm Set Screw	20
31058	Roll Bar Ballstuds, blue	2
31305	Turnbuckle Eyelets	14
31500	M3 x 2.5mm Set Screw	6
31511	M2 x 5mm SHCS	6
31701	TC7 Anti-Roll Bar Mount Set	1
31703	TC7 Front Anti-Roll Bar, 1.3mm (gray)	1
31704	TC7 Front Anti-Roll Bar, 1.4mm (blue)	1
31705	TC7 Front Anti-Roll Bar, 1.5mm (yellow)	1
31707	TC7 Rear Anti-Roll Bar, 1.1mm (green)	1
31708	TC7 Rear Anti-Roll Bar, 1.2mm (white)	1
31709	TC7 Rear Anti-Roll Bar, 1.3mm (gray)	1

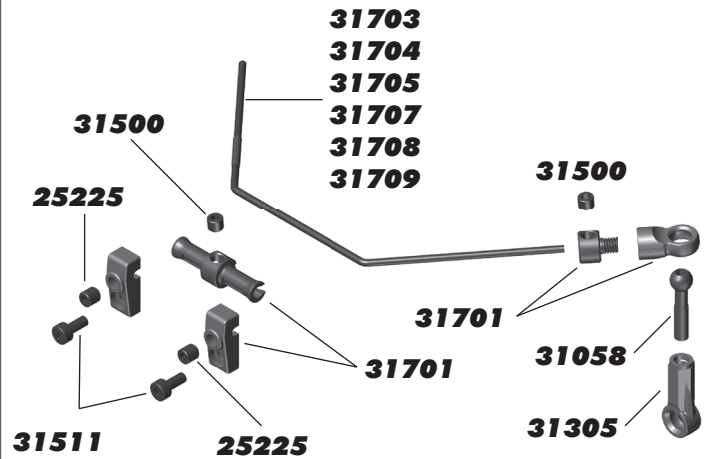

:: Turnbuckles

1402	FT Blue Titanium Turnbuckles 1.375"	Pr.
1405	FT Blue Titanium Turnbuckle 1.875"	Pr.
1418	FT Blue Titanium Turnbuckle 0.825"	Pr.
31305	Turnbuckle Eyelet	14

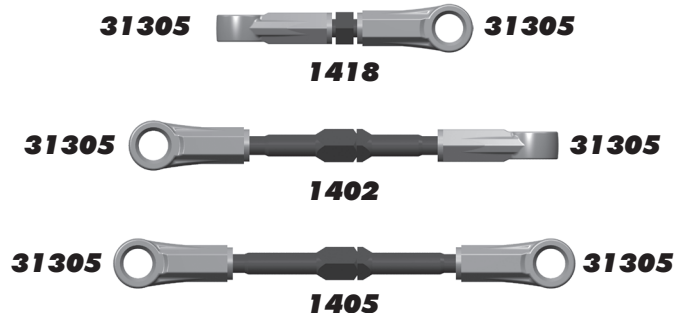

:: Front Spool

31162	Axle Shim Kit	1
31175	Oneway/Spool Pulley	1
31339	TC6 Spool Kit	1
31341	TC6 Spool Outdrives	4
31342	TC6 Spool Hub	1
31350	M2.5 x 10mm FHCS	6
31510	M2x4mm BHCS	6
31615	TC6.2 Diff Bearing Cam Set	1
91563	FT Bearing 10 x 15 x 4mm	4

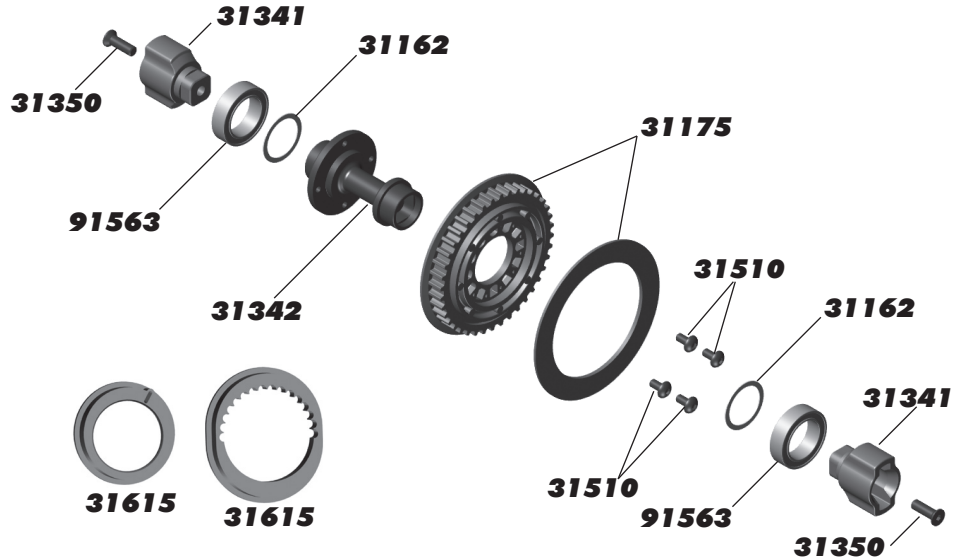

:: Rear Gear Differential

4675	M2.5 x 6mm FHCS	6
5450	Silicone Diff Fluid 1,000CST	1
5451	Silicone Diff Fluid 2,000CST	1
5452	Silicone Diff Fluid 3,000CST - Kit	1
5444	Silicone Diff Fluid 4,000CST	1
5453	Silicone Diff Fluid 5,000CST	1
5446	Silicone Diff Fluid 6,000CST	1
5454	Silicone Diff Fluid 7,000CST	1
5465	Silicone Diff Fluid 1,000,000CST	1
31162	Axle Shim Kit	1
31344	TC6 Gear Diff	1
31345	TC6 Gear Diff Rebuild	1
31346	TC6 Gear Diff Outdrives	2
31347	TC6 Gear Diff Case, O-Ring, Pulley	1
31348	TC6 Gear Diff Pins & Shims	1
31349	TC6 Gear Diff Seals	1
31615	TC6.2 Diff Bearing Cam Set	1
91563	FT Bearing 10 x 15 x 4mm	4

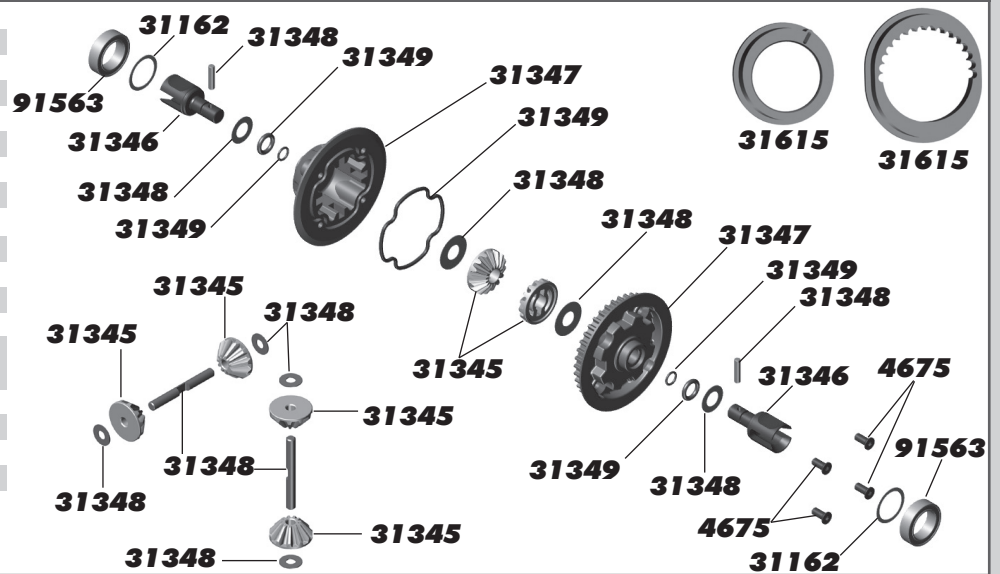

:: Spur Gear Assembly

25202	M3 x 10mm FHCS	20
31314	Spur Gear Hub	1
31319	Spur Clamping Ring	1
31320	Spur Pulley, 20T	2
31333	Spur Gear (87T/48P)	1
31530	M3 x 5mm BHCS	6
31541	M3 x 6mm FHCS	6
31664	TC7 Spur Gear Shaft	1
31731	FT 4x8x3mm Flanged Bearing	4
89229	Blue Countersunk Washers	10

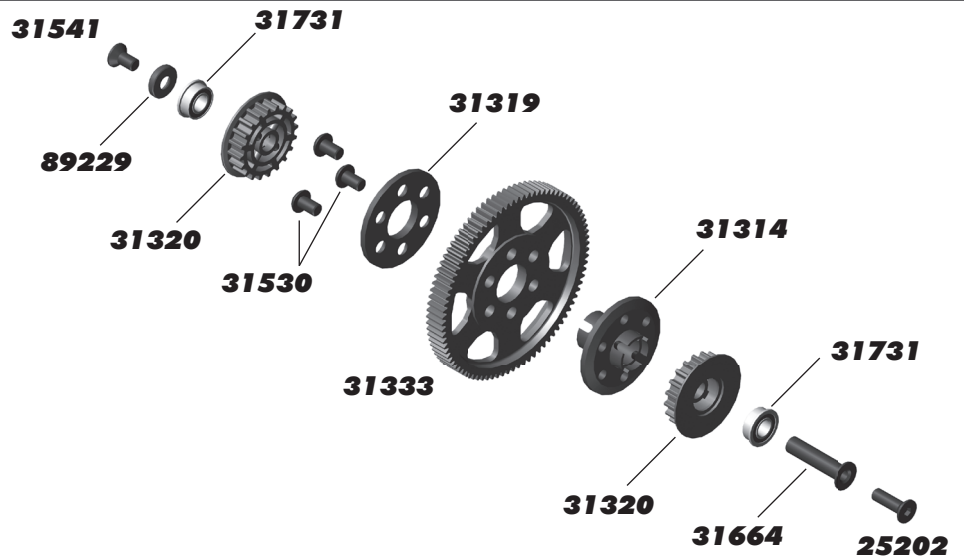

:: Steering Bellcrank and Servo Mounts

7336	Steering Servo Mount Kit	1
7337	.250" x .125" x .015" Washer	4
25202	M3 x 10mm FHCS	20
25211	M3 x 10mm BHCS	20
31283	5mm Ballstud, long	6
31285	Ballstuds, long, 10mm	6
31286	Aluminum Ballstud Washers, Set	1
31374	FT TiN 3.25mm Ballstud, short	2
31530	M3 x 5mm BHCS	6
31532	M3 x 8mm BHCS	6
31541	M3 x 6mm FHCS	6
31550	FT M3 Locknut, blue aluminum	6
31657	TC7 Servo Mount Brace	1
31665	TC7 Steering Rack Set	1
31666	TC7 Steering Bellcrank	2
31667	TC7 Steering Bellcrank Post Set	1
31669	TC7 Servo Mount Set	1
31732	FT 4x7x2.5mm Bearing	4
89007	Steering Servo Horn & Ring	1

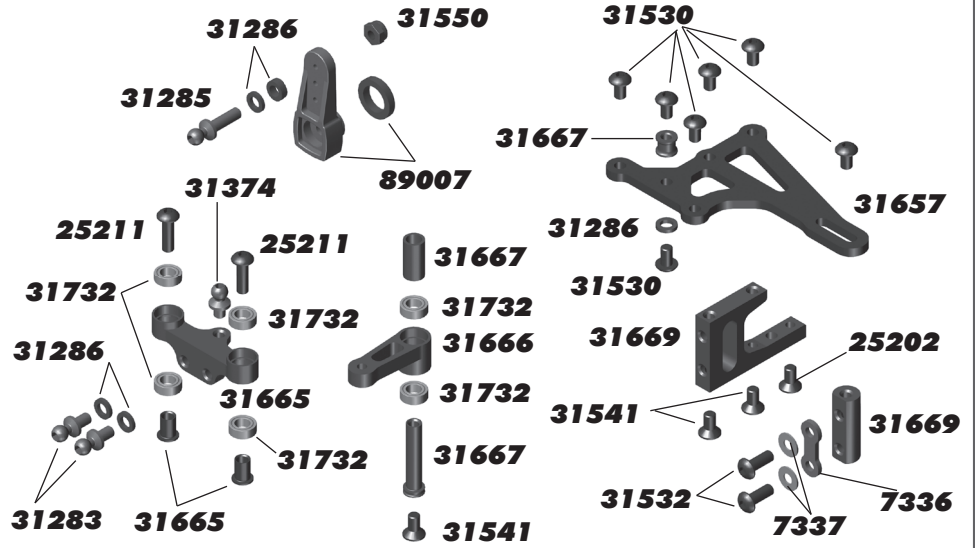

:: Front Bumper

1736	FT Body Clips, short	6
3897	Pivoting Body Mounts, Set	1
4673	M2.5 x 4mm BHCS	6
25201	M3 x 8mm FHCS	20
25202	M3 x 10mm FHCS	20
31623	TC6.2 Bumper Set	1
31624	TC6.2 Foam Bumper	1
31625	TC6.2 Body Post Set	1

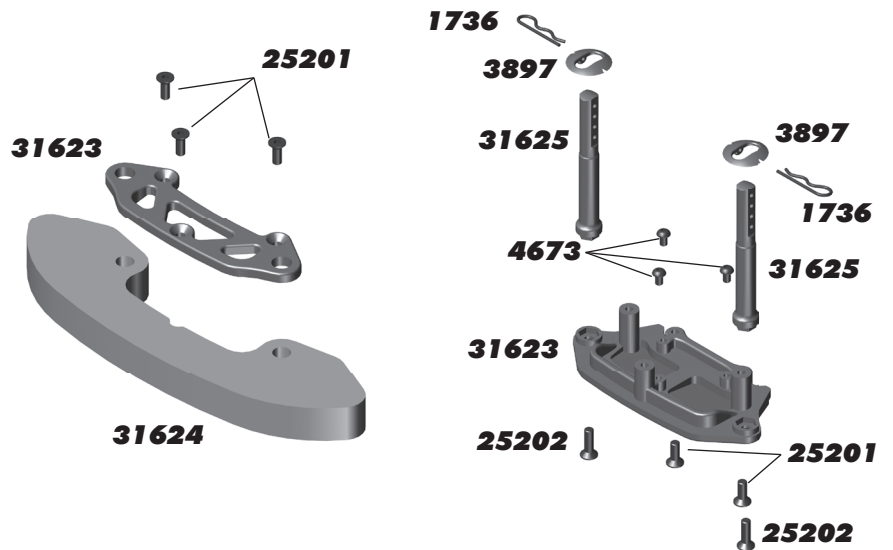

:: Front and Rear Shock Towers

1736	FT Body Clips, short	6
3897	Pivoting Body Mounts, Set	1
4637	FT Pivot Balls	8
31283	Ballstuds, long, 5mm	6
31286	Aluminum Ballstud Washers, Set	1
31531	M3 x 6mm BHCS	6
31532	M3 x 8mm BHCS	6
31541	M3 x 6mm FHCS	6
31613	TC6.2 Bearing Cap (A)	2
31614	TC6.2 Bearing Cap (B)	2
31625	TC6.2 Body Post Set	1
31655	TC7 Front Tower	1
31656	TC7 Rear Tower	1
31660	TC7 Bulkhead	1

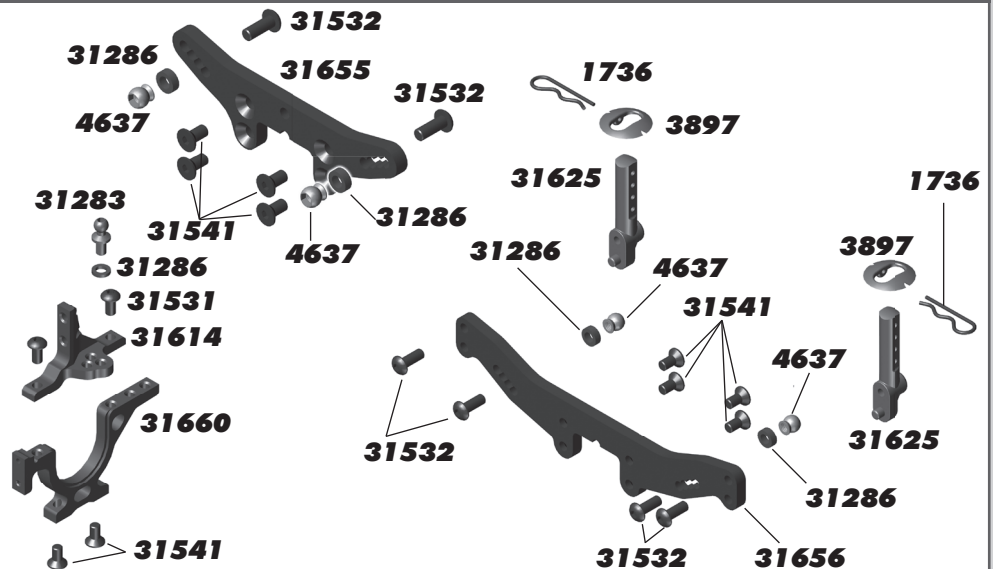

:: Front Bulkhead

4637	FT Pivot Balls	8
4670	M3 x 8mm Set Screw	6
25211	M3 x 10mm BHCS	20
25225	M3 x 3mm Set Screw	20
25227	M4 x 8mm Setscrew	20
31112	1/16" x 5/16" Dowel Pins	8
31283	Ballstuds, long, 5mm	6
31285	Ballstuds, long, 10mm	6
31286	Aluminum Ballstud Washers, Set	1
31370	TC6.1 Axle Crush Tubes	4
31621	TC6.2 Inner Hinge Pin Ball Set	1
31670	TC7 Wheel Hex, 5mm	2
31673	TC7 Front Suspension Arm	Pr.
31677	TC7 Hinge Pin Set	1
31678	TC7 Caster Block, 4 deg	Pr.
31679	TC7 Steering Block	Pr.
31680	TC7 King Pin Bushing	2
91148	M4 Locknut, w/flange and knurl	8
91560	FT Bearing 5 x 10 x 4mm	4
91611	M1.6 x 5mm SHCS	4

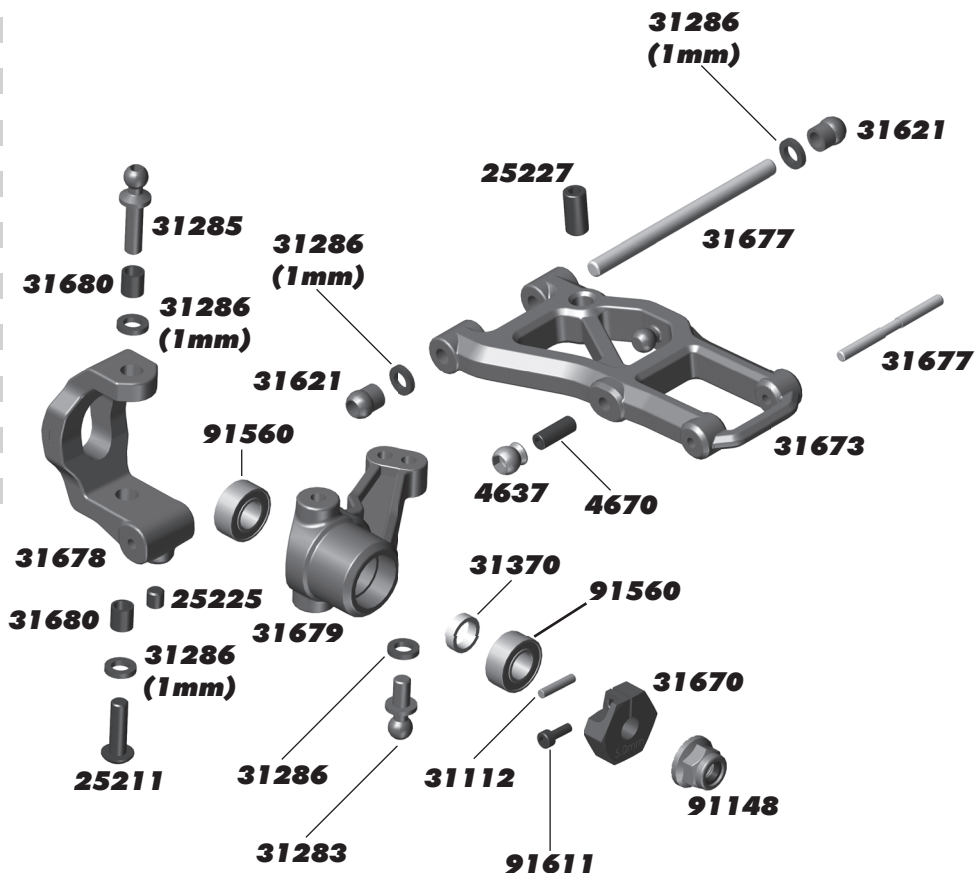

:: Rear Bulkhead

4637	FT Pivot Balls	8
4670	M3 x 8mm Set Screw	6
25225	M3 x 3mm Set Screw	20
25227	M4 x 8mm Setscrew	20
31112	1/16" x 5/16" Dowel Pins	8
31284	8mm Ballstud, long	6
31286	Aluminum Ballstud Washers, Set	1
31370	TC6.1 Axle Crush Tubes	4
31621	TC6.2 Inner Hinge Pin Ball Set	1
31670	TC7 Wheel Hex, 5mm	2
31674	TC7 Rear Suspension Arm	Pr.
31677	TC7 Hinge Pin Set	1
31681	TC7 Hub, 0 deg.	Pr.
91148	M4 Locknut, w/flange and knurl	8
91560	FT Bearing 5 x 10 x 4mm	4
91611	M1.6 x 5mm SHCS	4

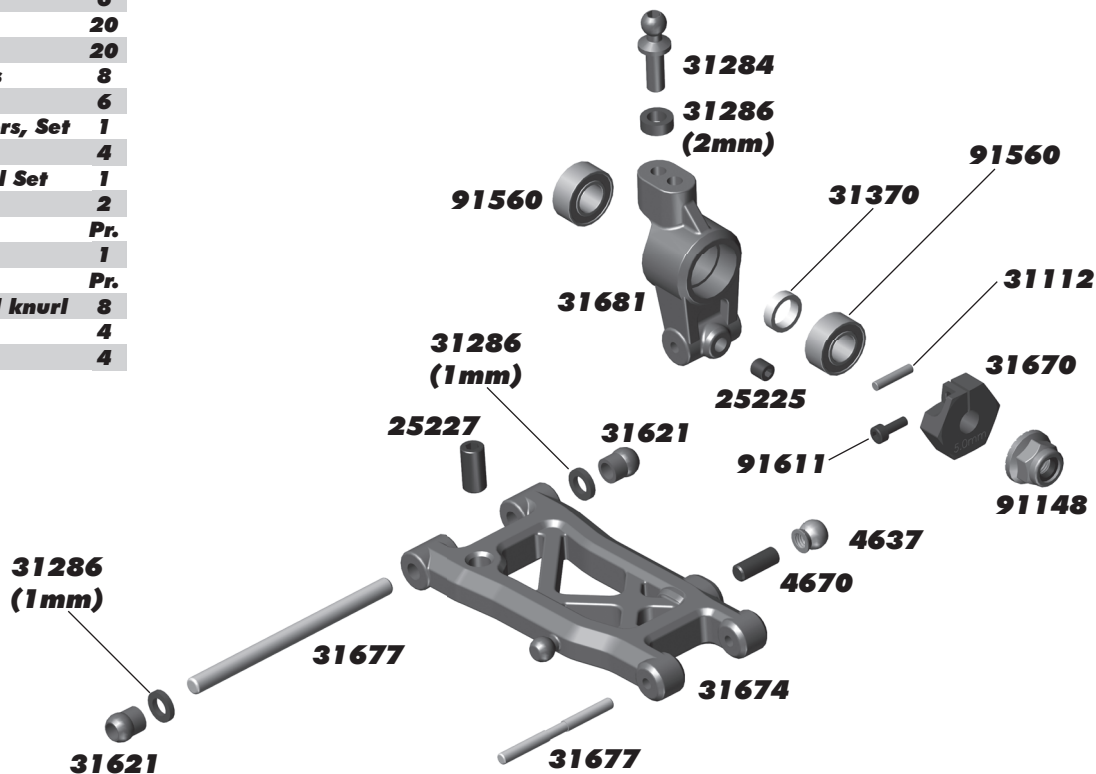

:: Motor Mount / Battery Mount

31286	Aluminum Ballstud Washers, Set	1
31532	M3x8mm BHCS	6
31541	M3x6mm FHCS	8
31626	TC6.2 LiPo Brace Set	1
31663	TC7 Motor Mount	1

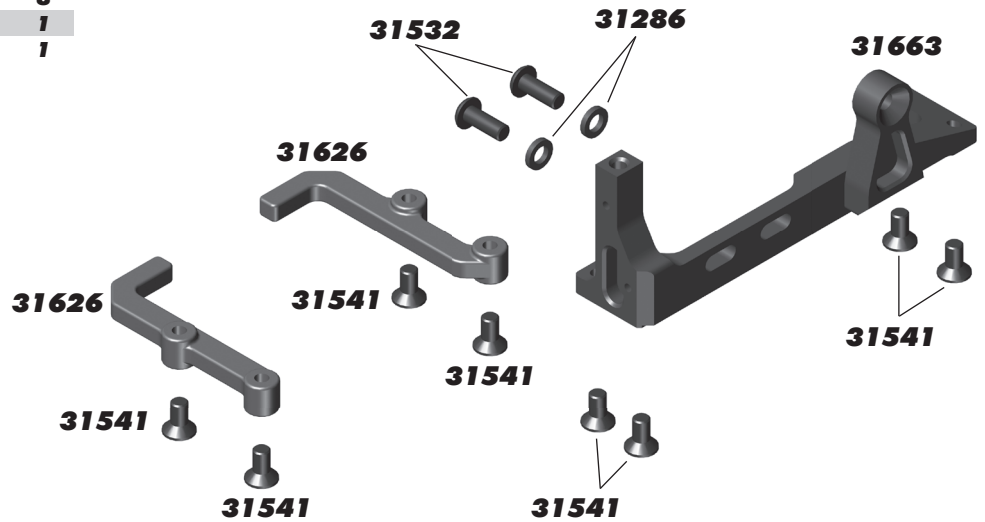

:: Chassis / Top Plate / Belts / Antenna / Arm Mounts

4617	Front Bulkhead Shim Set	1
6338	Antenna Tube 12", black	1
25225	M3 x 3mm Set Screw	20
31530	M3 x 5mm BHCS	6
31541	M3 x 6mm FHCS	6
31618	TC6.2 Outer Arm Mount	1
31619	TC6.2 Inner Arm Mount	1
31620	TC6.2 Arm Mount Insert Set	1
31626	TC6.2 LiPo Brace /Antenna Mount Set	1
31650	TC7 Chassis	1
31653	TC7 Top Plate	1
31658	TC7 Front Belt	1
31659	TC7 Rear Belt	1

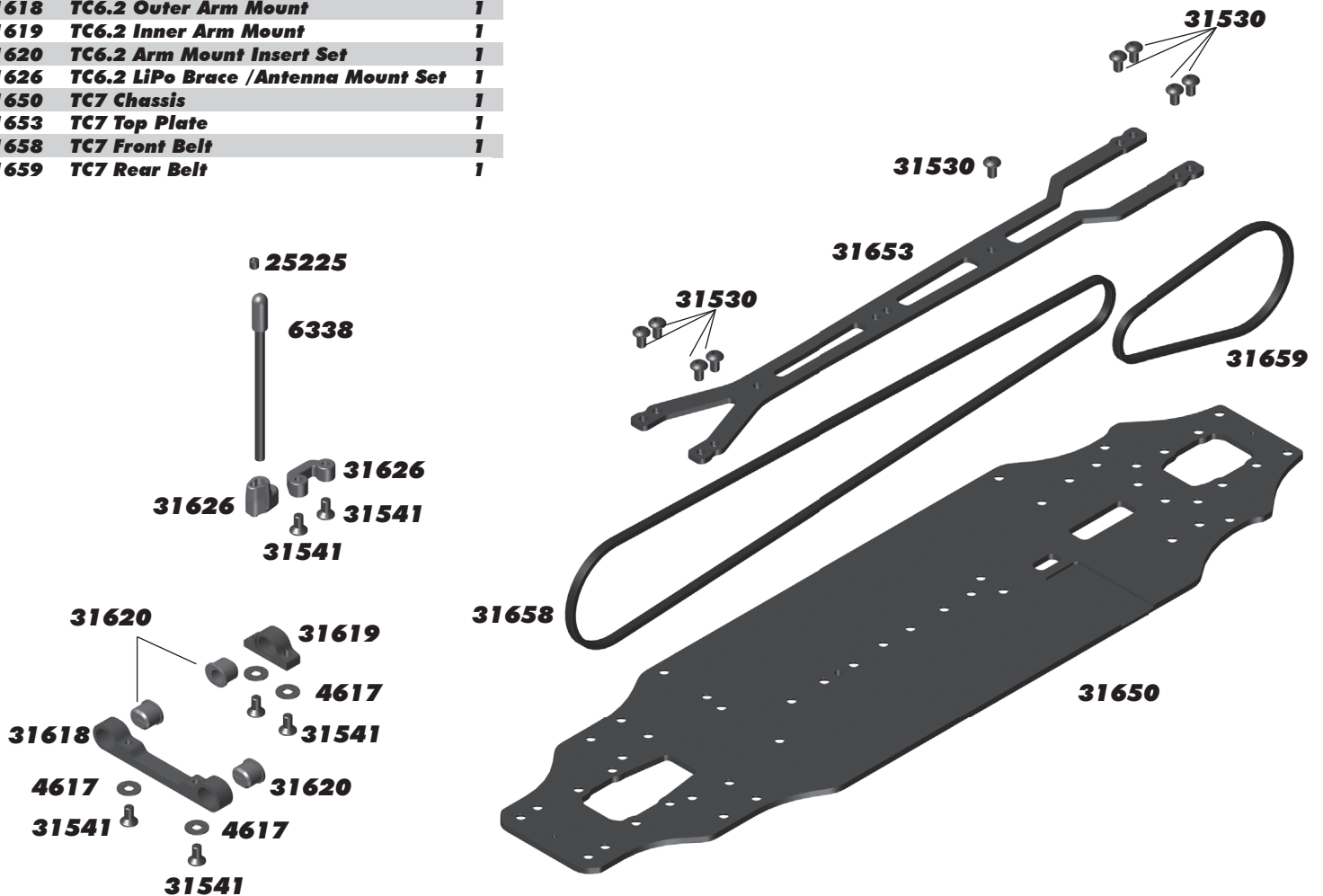

:: Lubes & Adhesives / Misc.

1105	FT Green Slime Shock Lube	1
1596	FT Locking Adhesive	1
1597	FT Tire Adhesive, Medium	1
5450	Silicone Diff Fluid 1,000CST	1
5451	Silicone Diff Fluid 2,000CST	1
5452	Silicone Diff Fluid 3,000CST	1
5444	Silicone Diff Fluid 4,000CST	1
5453	Silicone Diff Fluid 5,000CST	1
5446	Silicone Diff Fluid 6,000CST	1
5447	Silicone Diff Fluid 15,000CST	1
5454	Silicone Diff Fluid 7,000CST	1
5455	Silicone Diff Fluid 10,000CST	1
5456	Silicone Diff Fluid 20,000CST	1
5457	Silicone Diff Fluid 30,000CST	1
5458	Silicone Diff Fluid 60,000CST	1
5448	Silicone Diff Fluid 80,000CST	1
5459	Silicone Diff Fluid 100,000CST	1
5461	Silicone Diff Fluid 200,000CST	1
5463	Silicone Diff Fluid 500,000CST	1
5465	Silicone Diff Fluid 1,000,000CST	1
6588	Black Grease - 4cc	1
6591	S.Diff Lube - 4cc	1
6636	Silicone Grease - 4cc	1
6727	Servo Tape	2
9787	Chassis Protective Sheet	1



1596

:: Decals

716	Reedy 2009 Sticker Set	1
3816	American Bumper Sticker	1
3820	AE Logo Decal Sheet	1
3834	AE Blue Embossed Logo Sticker	2
31740	TC7 Decal Sheet	1

:: Factory Team and Option Parts

1401	FT Blue Titanium Turnbuckle 1.300"	2
1404	FT Blue Titanium Turnbuckle 1.775"	2
1734	FT Blue Body Clip, 4 long, 6 short	10
1735	FT Blue Body Clip, long	4
1736	FT Blue Body Clip, short	6
3927	Radial Heatsink, narrow	1
3928	Radial Heatsink, wide	1
4617	12R5 Front Bulkhead Shims (0.5, 1.0, 2.0)mm 4 ea	12
25391	FT 4mm Locknuts, blue	10
31280	5mm Ballstud, short	6
31281	8mm Ballstud, short	6
31282	10mm Ballstud, short	6
31283	5mm Ballstud, long	6
31284	8mm Ballstud, long	6
31285	10mm Ballstud, long	6
31286	Aluminum Ballstud Washer, Set	1
31288	Ti Nitride Ballstuds 5mm, short	2
31289	Ti Nitride Ballstuds 8mm, short	2
31290	Ti Nitride Ballstuds 10mm, short	2
31291	Ti Nitride Ballstuds 5mm, long	2
31292	Ti Nitride Ballstuds 8mm, long	2
31293	Ti Nitride Ballstuds 10mm, long	2
31296	TC6 Ballast Weight	1
31339	TC6 Spool Kit	1
31344	TC6 Gear Differential Kit	1
31441	10-Spoke Wheel, black	2
31442	5-Spoke Wheel, black	2
31443	5-Spoke Wheel, white	2
31466	5-Spoke Wheel, orange	2
31550	M3 Aluminum Lock Nut, blue	6
31551	M4 Aluminum Flange Lock Nut, blue	6
31629	TC6.2 Arm Mount Shims (outer)	4ea.
31630	TC6.2 Arm Mount Shims (inner)	2ea.
31632	TC6.2 DCV Kit, builds 2 DCV's (requires #91156 Bearings, 5 x 10 x 3)	1
31633	TC6.2 DCV Rebuild Kit	1
31634	TC6.2 DCV Stub Axle	1
31635	TC6.2 DCV Bone	1

:: Factory Team and Option Parts Cont.

31636	TC6.2 DCV Coupler Tube	1
31637	TC6.2 Gear Diff Outdrive, Steel	1
31638	TC6.2 Spool Outdrive, Steel	1
31639	TC6.2 Belt Tensioner Kit	1
31640	TC6.2 Fan Mount Set	1
31641	TC6.2 30mm Cooling Fan	1
31652	TC7 Chassis, Aluminum	1
31668	TC7 Floating Steering Bellcrank Post	1
31671	TC7 Wheel Hex, 4mm	2
31672	TC7 Wheel Hex Spacer Set	1
31690	TC7 Shock Piston, (3x1.1G)	4
31730	TC7 Bearing Kit	1
91156	Bearing, 5 x 10 x 3, metal (used with #31632)	2
91493	FT Low Friction X-Rings	8

:: Pinions / Spur Gears

8253	16T 48P Pinion Gear	1	8269	32T 48P Pinion Gear	1
8254	17T 48P Pinion Gear	1	8270	33T 48P Pinion Gear	1
8255	18T 48P Pinion Gear	1	8271	34T 48P Pinion Gear	1
8256	19T 48P Pinion Gear	1	8272	35T 48P Pinion Gear	1
8257	20T 48P Pinion Gear	1	3921	69T 48P Spur Gear	1
8258	21T 48P Pinion Gear	1	3922	72T 48P Spur Gear	1
8259	22T 48P Pinion Gear	1	3923	75T 48P Spur Gear	1
8260	23T 48P Pinion Gear	1	3924	66T 48P Spur Gear	1
8261	24T 48P Pinion Gear	1	3994	73T 48P Spur Gear	1
8263	26T 48P Pinion Gear	1	4462	100T 64P Spur Gear	1
8264	27T 48P Pinion Gear	1	4615	96T 64P Spur Gear	1
8265	28T 48P Pinion Gear	1	31332	80T 48P Spur Gear	1
8266	29T 48P Pinion Gear	1	31333	87T 48P Spur Gear	1
8267	30T 48P Pinion Gear	1	31334	106T 64P Spur Gear	1
8268	31T 48P Pinion Gear	1	31335	115T 64P Spur Gear	1

:: Reedy Motors

252	Sonic 540-M3 25.5	1
253	Sonic 540-M3 21.5	1
254	Sonic 540-M3 17.5	1
255	Sonic 540-M3 13.5	1
256	Sonic 540-M3 10.5	1
257	Sonic 540-M3 9.5	1
258	Sonic 540-M3 8.5	1
259	Sonic 540-M3 8.0	1
260	Sonic 540-M3 7.5	1
261	Sonic 540-M3 7.0	1
262	Sonic 540-M3 6.5	1
263	Sonic 540-M3 6.0	1
264	Sonic 540-M3 5.5	1
265	Sonic 540-M3 5.0	1
266	Sonic 540-M3 4.5	1
267	Sonic 540-M3 4.0	1
268	Sonic 540-M3 3.5	1
269	Sonic 540-M3 SS 17.5 1S	1
270	Sonic 540-M3 SS 13.5 1S	1
271	Sonic 540-M3 Spec Rotor 12.0	1
272	Sonic 540-M3 Spec Rotor 12.2	1
273	Sonic 540-M3 Spec Rotor 12.5	1
274	Sonic 540-M3 Mod Rotor 12.3	1
275	Sonic 540-M3 Mod Rotor 12.5	1
276	Sonic 540-M3 Mod Rotor 13.0	1
277	Sonic 540-M3 Stainless Steel Bearing Set	1
278	Sonic 540-M3 Ceramic Bearing Set	1
279	Sonic 540-M3 Sensor Assembly	1
280	Sonic 540-M3 Rotor Spacer Set	1
281	Sonic 540-M3 Case Screws	1
282	Sonic 540-M3 Motor Insulator Set	1
283	Sonic 540-M3 Motor Mounting Plate	1

:: Reedy Batteries and Chargers

302	AA Alkaline 1.5V (4)	1
304	LiPo Pro TX/RX Battery 1600mAh 7.4V Flat	1
305	LiFe Pro TX/RX Battery 1300mAh 6.6V Flat	1
309	LiPo 65C 7000mAh 7.4V	1
313	LiPo 65C 7000mAh 7.4V 5mm	1
315	LiPo Pro TX/RX Battery 2100mAh 7.4V Flat	1
316	LiPo 65C 5000mAh 7.4V	1
321	LiPo 70C 6000mAh 7.4V	1
607	Charge Harness 2S Standard Pack 4mm	1
611	Charge Harness 2S Standard Pack 5mm	1
637	LiPo TX Battery - M11X 2500mAh 7.4V	1
638	LiFe RX Battery 1700mAh 6.6V	1
639	LiPo RX Battery 1200mAh 7.4V	1
640	LiPo RX Battery 2300mAh 7.4V	1
739	Wolfpack LiPo 5500mAh 7.4V 60C	1
996	5.0mm 1S-2S Balance Charge lead w/SP Clip	1
997	4.0mm 1S-2S Balance Charge lead w/SP Clip	1
999	Saddle Pack Balance Charge Clip	1
27200	1216-C2 Dual AC/DC Comp. Battery Charger	1

:: Reedy Electronics

27000	Blackbox 410R 1S-2S Competition ESC	1
27001	Blackbox 410R 1S-2S Comp. ESC w/Programmer	1
27020	Blackbox ESC PROgrammer	1
27021	Blackbox 410R Fan w/Screws	1
27022	Blackbox 410R Heavy-Duty Capacitor Unit	1
27023	Blackbox 410R XL Capacitor Unit	1
27024	Blackbox 410R Pro Capacitor Unit	1
27025	Blackbox ESC PROgrammer Wire Extension	1
27100	RS1206 Digital HV Hi-Speed Competition Servo	1
27101	RT1508 Digital HV Hi-Torque Competition Servo	1
27102	RS1206 Servo Case Set w/screws	1
27103	RS1206 Servo Gear Set	1
27104	RT1508 Servo Case Set w/screws	1
27105	RT1508 Servo Gear Set	1

:: Reedy Accessories

643	Low Profile Bullet Plug 4mm x 14mm (2)	1
644	Low Profile Bullet Plug 4mm x 14mm (10)	1
645	Low Profile Bullet Plug 5mm x 14mm (2)	1
646	Low Profile Bullet Plug 5mm x 14mm (10)	1
647	Silicone Wire 12AWG-Black (1m)	1
648	Silicone Wire 14AWG-Black (1m)	1
649	Silicone Wire 16AWG-Black (1m)	1
650	Shrink Tubing - 15pcs 4.5mm x 20mm	1
654	4.0mm Bullet Plugs (2M, 2F)	1
655	4.0mm Bullet Plugs (2M, 10F)	1
656	4.0mm Bullet Plugs (10F)	1
657	4.0mm Bullet Plugs (100F)	1
658	4.0mm Bullet Plugs (10M)	1
659	4.0mm Bullet Plugs (30M)	2
669	5.0mm Bullet Plugs (2M)	1
747	Silicone Wire 12AWG-Black (30m)	1
748	Silicone Wire 14AWG-Black (30m)	1
749	Silicone Wire 16AWG-Black (30m)	1
790	Silicone Wire 13AWG-Black (1m)	1
791	Silicone Wire 13AWG-Black (30m)	1
792	Low Profile Caged Bullet Plug 4mm x 14mm (2)	1
793	Low Profile Caged Bullet Plug 4mm x 14mm (10)	1
794	Low Profile Caged Bullet Plug 5mm x 14mm (2)	1
795	Low Profile Caged Bullet Plug 5mm x 14mm (10)	1
978	Flat Sensor Wire 70mm	1
979	Flat Sensor Wire 110mm	1
980	Flat Sensor Wire 150mm	1
981	Flat Sensor Wire 200mm	1
982	Flat Sensor Wire 270mm	1
994	Flat Sensor Wire 125mm	1
995	Flat Sensor Wire 175mm	1

:: XP Electronics

29138	XP SC500 Brushless ESC	1
29139	XP SC900-BL ESC	1
29141	XP SC450-BL Brushless ESC	1
29142	XP ESC Fan Option	1
29143	XP SC700-BL Brushless ESC	1
29144	XP SC1200 Brushless ESC	1
29166	XP DS1313 Digital Servo	1
29167	XP DS1015 Digital Servo	1
29168	XP DS1510MG Servo	1
29209	Gear Set, DS1313	1
29210	Gear Set, DS1015	1
29211	Servo Case, DS1313/DS1015	1
29212	Accessory Pack, DS1313/DS1015	1
29214	TRS 403-SSi Receiver	1
29215	XP2G Radio System	1
29216	XP3G Radio System	1
29254	Receiver Antenna	1

:: Qualifier Series Vehicles

7062	Pro SC 4x4 RTR, 1/10 Scale (ready-to-run)	1
7070	Pro Rally 4wd RTR, 1/10 Scale (ready-to-run)	1
20111	Rival Mini Monster Truck 1/18 Scale (ready-to-run)	1
20119	APEX Mini Touring 1/18 Scale (ready-to-run)	1
20510	RIVAL Electric Monster Truck RTR, 1/8 Scale (ready-to-run)	1
30112	APEX Touring V-Type, 1/10 Scale (ready-to-run)	1
30113	APEX Scion Racing FR-S 1/10 Scale (ready-to-run)	1
30113D	APEX Scion Racing FR-S Drift 1/10 Scale (ready-to-run)	1
30114	APEX Scion Racing tC 1/10 Scale (ready-to-run)	1
30114D	APEX Scion Racing tC Drift 1/10 Scale (ready-to-run)	1

:: 1/18 Kits and RTR's

20103	RC18B2 - RC18T2 Team Kit	1
20121	SC18 RTR Brushless (ready-to-run)	1

:: 1/12, 1/10 Kits and RTR's

4020	FT 12R5.2 Kit	1
7030	SC10 KMC Wheels Race Truck RTR (ready-to-run)	1
7038	FT SC10.2 Kit	1
7039	RC10T4.2 RS RTR 2.4GHz Brushless (ready-to-run)	1
7046	SC10 RS RTR, Lucas Oil (ready-to-run)	1
7049	SC10 RS RTR, Rockstar/Makita (ready-to-run)	1
9042	RC10B4.2 RS RTR 2.4GHz Brushless (ready-to-run)	1
9050	SC10B RS RTR (ready-to-run)	1
9063	FT B44.3 4WD Buggy Kit	1
30101	TC4 Club Racer 4WD Touring Car Race Roller	1
30120	FT TC7 Kit	1
70001	RC10T5M Team Kit	1
70006	RC10SC5M Team Kit	1
90000	RC10B5M FT Lite	1
90001	RC10B5 Team Kit	1
90003	RC10B5M Team Kit	1

:: 1/8 Kits and RTR's

20502	MGT 8.0 Nitro RTR (ready-to-run)	1
20504	Limited Edition MGT 8.0 Nitro RTR, w/flag body (ready-to-run)	1
80907	RC8.2e Electric Buggy FT Kit	1
80908	RC8.2e Electric Buggy RTR (ready-to-run)	1
80909	RC8.2RS Nitro Buggy RTR (ready-to-run)	1
80912	RC8T Championship Edition	1
80914	RC8B3 Team Kit - Nitro	1
80916	RC8B3e Team Kit - Electric	1

:: RePlay Cameras

RP004	Replay XD1080 Mini Complete Camera System	1
RP005	Replay XD PrimeX Camera System	1
RP021	Replay XD1080 Lens Bezel Kit	1
RP022	Replay XD1080 Clear Lens Cover	1
RP023	Replay XD1080 Lens Bezel & Rear Cap O-Ring	1
RP029	Replay XD1080 HDMI to Mini-HDMI	1
RP030	Replay XD1080 Mini 8-pin USB Charge Data Cable	1
RP032	USB DC Car Charger 1A Stubby	1
RP034	Micro SDHC USB Reader	1
RP036	3M VHB 4991 Mount Adhesive for SnapTray	1
RP042	Replay XD Suction Cup Short Arm Base	1
RP043	Replay XD Skateboard Mount	1
RP044	Replay XD VHB SnapTray, Convex	1
RP045	Replay XD VHB SnapTray, Flat	1
RP046	Au Plug for Universal DC Wall Charger	1
RP047	Eu Plug for Universal DC Wall Charger	1
RP048	Uk Plug for Universal DC Wall Charger	1
RP049	Universal USB DC Wall Charger 1A	1
RP050	Au Plug for Uni DC Wall Charger	1
RP054	Replay ReView Field Monitor	1
RP055	Replay PrimeX Lens 5 pack	1
RP056	Replay PrimeX HDMI Cable	1
RP057	Replay PrimeX Deep Dive Waterproof Case	1
RP058	Replay PrimeX Heim Lock Mount	1
RP059	Replay PrimeX Low Boy Mount	1
RP060	Replay PrimeX Tilt Mount	1

:: Apparel

SP17**	AE INT'L T-Shirt - Black (S, M, L, XL-5XL)	1
SP18**	AE INT'L T-Shirt - White (S, M, L, XL-5XL)	1
SP19**	AE INT'L Hoodie - Black (S, M, L, XL-3XL)	1
SP20	AE Patch Trucker Hat	1
SP22**	Reedy Vintage '81 T-Shirt - Blue (S, M, L, XL-3XL)	1
SP23**	AE Splash T-shirt - Black (S, M, L, XL-5XL)	1
SP24**	AE Splash T-shirt - Blue (S, M, L, XL-5XL)	1
SP29**	Team Associated Countertop / Setup Mat	1
SP31**	Reedy Countertop / Setup Mat	1
SP32**	AE Kids T-shirt - Blue (S, M, L)	1
SP38	Reedy Trucker Hat	1
SP39	Reedy Patch	1
SP84**	Reedy 3D T-Shirt, Black (S, M, L, XL-3XL)	1
SP87**	AE 2013 Zip Hoodie (S, M, L, XL-3XL)	1
SP90**	AE Retro T-shirt, Blue (S, M, L, XL-5XL)	1
SP91**	AE Retro T-shirt, Black (S, M, L, XL-5XL)	1
SP92**	AE Retro T-shirt, White (S, M, L, XL-5XL)	1
SP93**	AE 2013 Worlds T-shirt - Blue (S, M, L, XL-5XL)	1
SP96**	AE Womens Retro - Pink (S, M, L, XL)	1
SP110*	Reedy R-Powered T-Shirt - Black (S, M, L, XL-3XL)	1
SP111*	Reedy W15 Sweatshirt - Black (S, M, L, XL-3XL)	1
SP420**	AE Pit Gloves (XL)	Pr.
SP421S	AE 2012 Hat, Black, Flat Bill, S/M	1
SP421L	AE 2012 Hat, Black, Flat Bill, L/XL	1
SP422S	AE 2012 Hat, Black, Curved Bill, S/M	1
SP422L	AE 2012 Hat, Black, Curved Bill, L/XL	1
SP423S	AE 2012 Hat, White, Flat Bill, S/M	1
SP423L	AE 2012 Hat, White, Flat Bill, L/XL	1
SP424S	AE 2012 Hat, White, Curved Bill, S/M	1
SP424L	AE 2012 Hat, White, Curved Bill, L/XL	1
SP425	FT Fluid Carrier	1
715	Reedy 2009 Track Banner	1
110684	Team Associated Track Banner	1
110685	Team Associated Cloth Banner	1

** Use part number plus the desired size when ordering!

:: Kicker

29269	KICKER KPw Wireless Speaker System, black	1
29270	KICKER KPw Wireless Speaker System, white	1

:: Tools

1111	FT Turnbuckle Wrench	1
1112	FT 4mm Turnbuckle Wrench	1
1450	On Road Ride Height Gauge	1
1541	FT Hex Driver Set, (7 pcs)	1
1542	FT .050" Silver Hex Driver	1
1543	FT 1/16" Black Hex Driver	1
1544	FT 1.5mm Purple Hex Driver	1
1545	FT 5/64" Blue Hex Driver	1
1546	FT 3/32" Gold Hex Driver	1
1547	FT 2.5mm Green Hex Driver	1
1548	FT 3mm Red Hex Driver	1
1554	FT Silver Spring Hook Tool	1
1564	FT 5.5mm Red Nut Driver	1
1567	FT 8mm Gold Nut Driver	1
1568	FT 5.5mm Short Nut Driver	1
1569	FT 7mm Nut Driver, T-Handle	1
1570	FT 5.5mm Short Nut Driver	1
1590	FT 3/32" Gold Ball Hex Driver	1
1592	FT Ball Hex Driver Set, (3 pcs)	1
1655	FT 8-Piece 1/4" Hex Drive Set	1
1656	FT 1/4" Hex Drive Handle, without tips	1
1657	FT 1/4" Hex Drive .050" Tip	1
1658	FT 1/4" Hex Drive 1/16" Tip	1
1659	FT 1/4" Hex Drive 5/64" - 2.0mm Tip	1
1660	FT 1/4" Hex Drive 3/32" Tip	1
1661	FT 1/4" Hex Drive 1.5mm Tip	1
1662	FT 1/4" Hex Drive 2.5mm Tip	1
1663	FT 1/4" Hex Drive 3/16" Nut Driver Tip	1
1664	FT 1/4" Hex Drive 1/4" Nut Driver Tip	1
1665	FT 1/4" Hex Drive 11/32" Nut Driver Tip	1
1666	FT 1/4" Hex Drive 5.5mm Nut Driver Tip	1
1667	FT 1/4" Hex Drive 7.0mm Nut Driver Tip	1
1668	FT 1/4" Hex Drive 8.0mm Nut Driver Tip	1
1669	FT 1/4" Hex Drive 5/64" - 2.0mm Ball End Tip	1
1670	FT 1/4" Hex Drive 3/32" Ball End Tip	1
1671	FT 1/4" Hex Drive Standard Screwdriver Tip	1
1672	FT 1/4" Hex Drive Phillips Screwdriver Tip	1
1673	FT 1/4" Hex Drive 2.5mm Ball End Tip	1
1674	FT 1/4" 5 Piece Power Tool Tips Set (5/64-2.0mm, 1.5mm, 2.5mm, 5/64"- 2.0mm ball, 2.5mm ball)	1
1675	FT Shock Shaft Pliers	1
1679	FT T-Handle Ratchet Driver	1
1719	FT Camber + Track Width Tool	1
1737	FT Body Scissors	1
3718	12 Inch Nylon Wire Ties	12
3719	6 Inch Nylon Wire Ties	12
3720	8 Inch Nylon Wire Ties	12
3987	FT Droop Gauge	1
6429	Shock Building Tool	1
6956	Molded Tools, Set	1
7709	4 Inch Nylon Wire Ties	12

Associated Electrics, Inc.
26021 Commercentre Drive
Lake Forest, CA 92630-8853 USA
<http://www.TeamAssociated.com>
<http://www.RC10.com>
[http://twitter/Team Associated](http://twitter/TeamAssociated)
<http://bit.ly/AEonFacebook>

call: (949) 544-7500

fax: (949) 544-7501

Check out the following web sites for all of our electric kits, current products, new releases, setup help, tips, and racing info!

www.TeamAssociated.com - www.RC10.com

Drivers

Team Setup

Date:

Tracks

Event:

Conditions:

Rev'd

Front

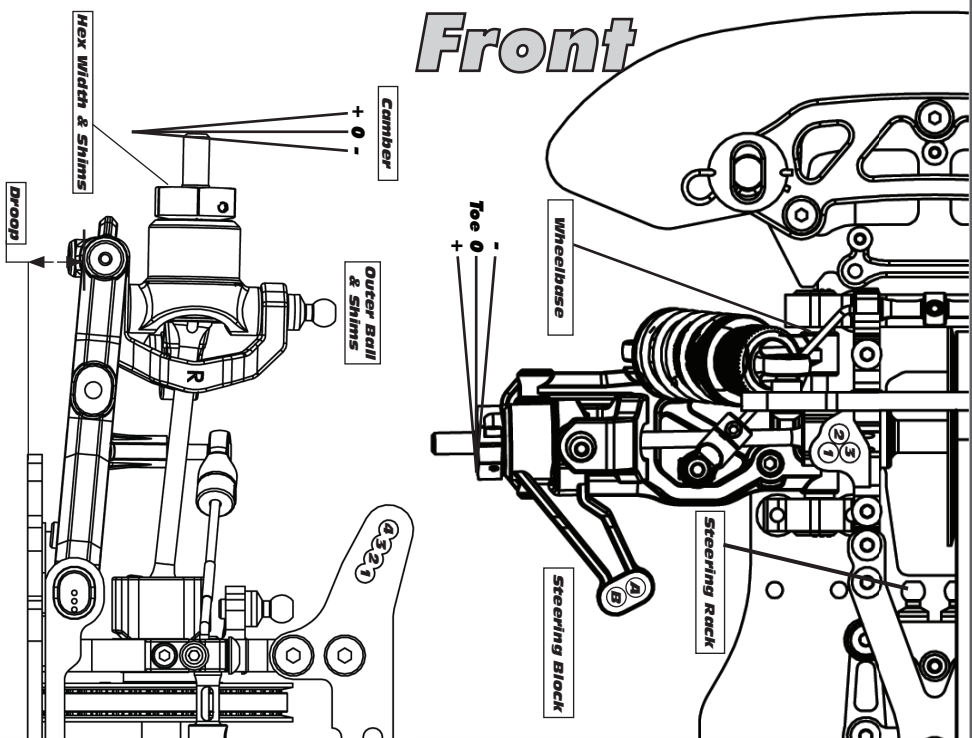

Front	Alignment	Rear
5.0mm	Ride Height	5.2mm
-2 deg	Camber	-2 deg
4 deg	Caster	N/A
N/A	Rear Hub Toe	0 deg
+0.5 deg	Toe (Total)	-3 deg
5mm	Hex Width & Shims	5mm
1mm	Wheelbase	1mm
Silver + 1mm	Steering Rack Ball & Shims	N/A
B	Steering Block Position	N/A
Silver + 1mm	Steering Block Ball & Shims	N/A

Notes:

Suspension Geometry

	1	2
2	Shock Position	2
1	Camber Link Position	1A
Silver + 1mm	Inner Ball & Shims	Silver + 1mm
Silver + 1mm	Outer Ball & Shims	Silver + 2mm
-3 Dot	Outer Arm Mount Insert	1 Dot
0.5mm	Outer Mount Shims	0.5mm
-3 Dot	Inner Arm Mount Insert	1 Dot
0.5mm	Inner Mount Shims	0.5mm
6	Droop	5
1.4 (Blue)	Anti-Roll Bar	1.2 (White)

Notes:

Shocks

37.5 wt	Oil	37.5 wt
1.1 x 3	Piston	1.1 x 3
25%	Rebound	25%
Blue	Spring	Blue

Notes:

Differentials

Spool	Type	Blue
Low	Setting	3,000 cst
9	Cam Position	Low
	Belt Tension Number	8

Notes:

Tires

Type	
Tire Diameter	
Insert & Wheel	
Additive & Amount	

Notes:

Chassis

Classis:	Top Plate:

Notes:

Notes:

For more setups, visit RC10.com and click on "Setup Sheets"

Rear

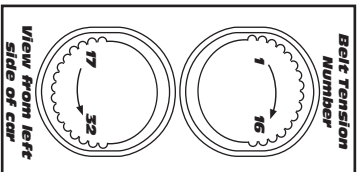
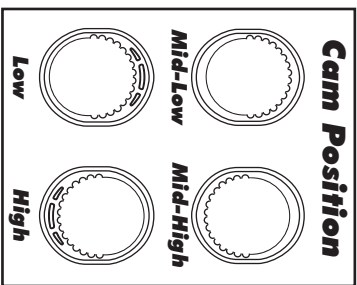
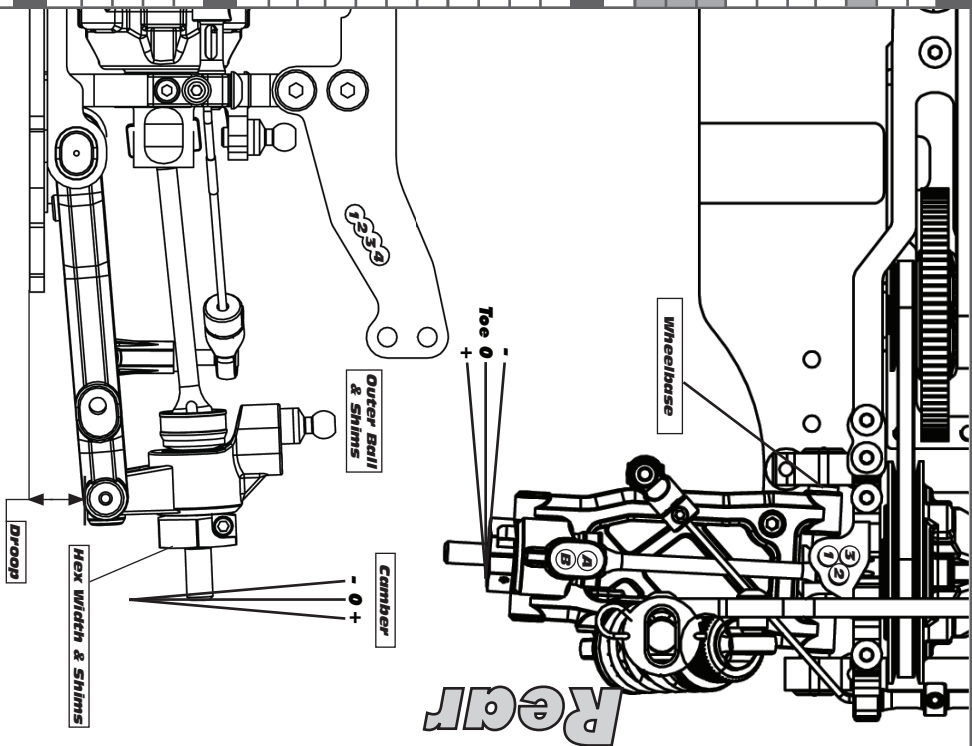

Motor

Gearing

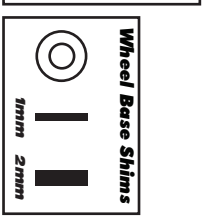
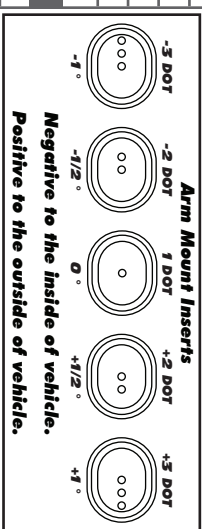

Transmitter

Speed Control

Turning Circle:

E.S.C. Type:

Steering Expo:

E.S.C. Settings:

Brake E.P.:

Software Version:

Throttle Expo:

Notes:

Battery Placement

Body & Wing

Notes:

Notes:

Drivers _____

Tracks _____

Event: _____

Date: _____

Conditions: _____

Rev 6/1

Front

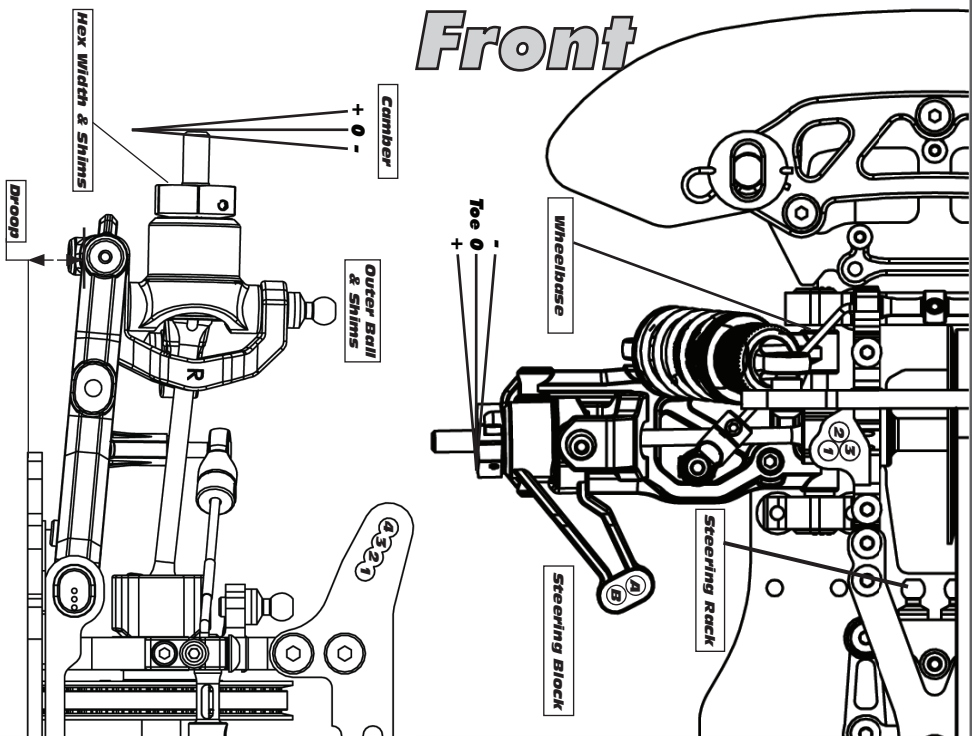

Front	Alignment	Rear
	Ride Height	
	Camber	
	Caster	N/A
N/A	Rear Hub Toe	
	Toe (Total)	
	Hex Width & Shims	
	Wheelbase	
	Steering Rack Ball & Shims	N/A
	Steering Block Position	N/A
	Steering Block Ball & Shims	N/A

Notes:

Suspension Geometry

Shock Position	
Camber Link Position	
Inner Ball & Shims	
Outer Ball & Shims	
Outer Arm Mount Insert	
Outer Mount Shims	
Inner Arm Mount Insert	
Inner Mount Shims	
Droop	
Anti-Roll Bar	

Notes:

Shocks

Oil	
Piston	
Rebound	
Spring	

Notes:

Differentials

Type	
Setting	
Camber Position	
Belt Tension Number	

Notes:

Tires

Type	
Tire Diameter	
Insert & Wheel	
Additive & Amount	

Notes:

Chassis

Classis:	
Top Plate:	

Notes:

Notes:

Notes:

For more setups, visit RC10.com and click on "Setup Sheets"

Rear

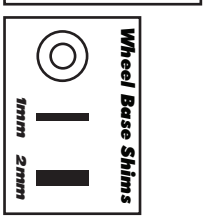
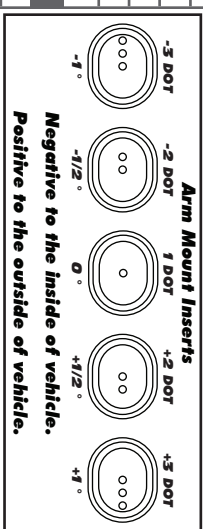
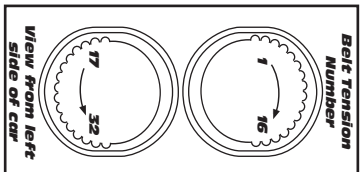
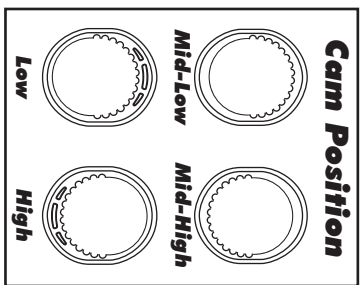
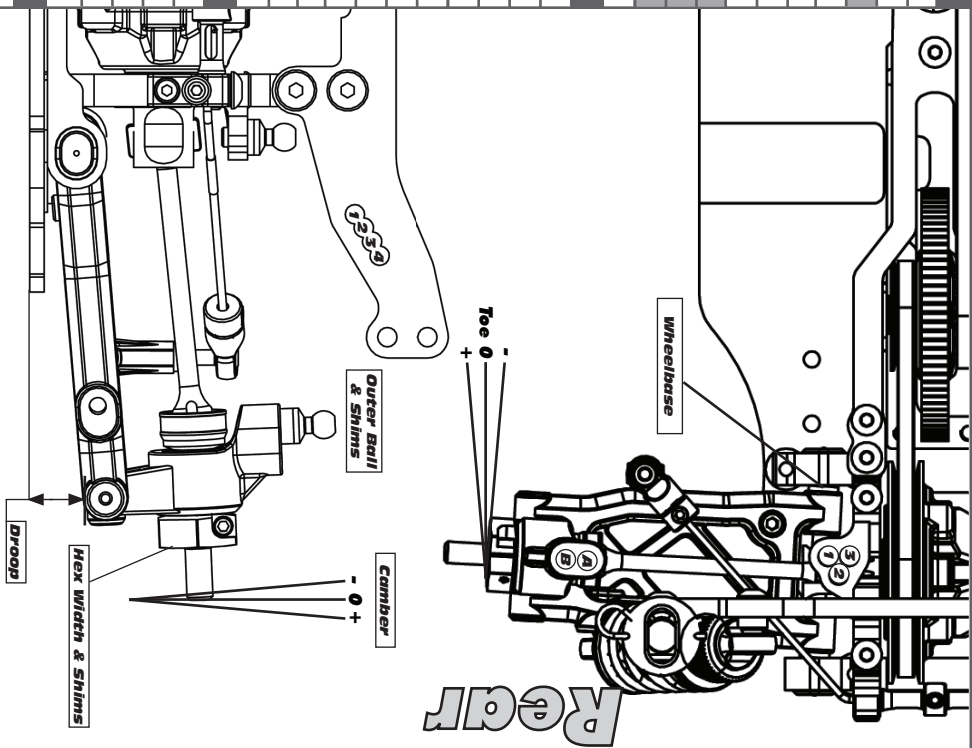

Transmitter

Turning Circle:

Steering Expo:

Brake E.P.:

Throttle Expo:

Battery Placement

Speed Control

E.S.C. Type:

E.S.C. Settings:

Software Version:

Notes:

Body & Wing

Notes:

Notes:



**Associated Electrics, Inc.
26021 Commercentre Dr.
Lake Forest, CA 92630 USA**

<http://www.TeamAssociated.com>

<https://www.RC10.com>

https://twitter/Team_Associated

<https://bit.ly/AEonFacebook>

call: (949) 544-7500 - fax: (949) 544-7501

**Check out the following web sites for all of our kits,
current products, new releases, setup help, tips, and racing info!
www.TeamAssociated.com - www.RC10.com**